

**Drum Movers and Palletizers with Geared Drum Tilt**

**Drum movers to palletize and dispense drum with geared drum tilt control**

This innovative design combines a V-shaped base to serve the corner of a pallet, with geared tilt control to dispense a drum.

**Hand Crank Geared Drum Tilt.** Shown with recommended [MORStop Tilt-Brake](#) option.

**V-Shaped Counterweighted Base enables Palletizing Drum**

**Models with AC, DC or Air Power Drum Lift**

**Capacity: 600 Lb. (272 kg)**

MADE  
IN  
USA



Model # 82A-GT-125  
with battery power drum lift



Model # 82A-GT  
with hand pump drum lift



Model # 82A-GT-125

Move a drum onto and off a pallet

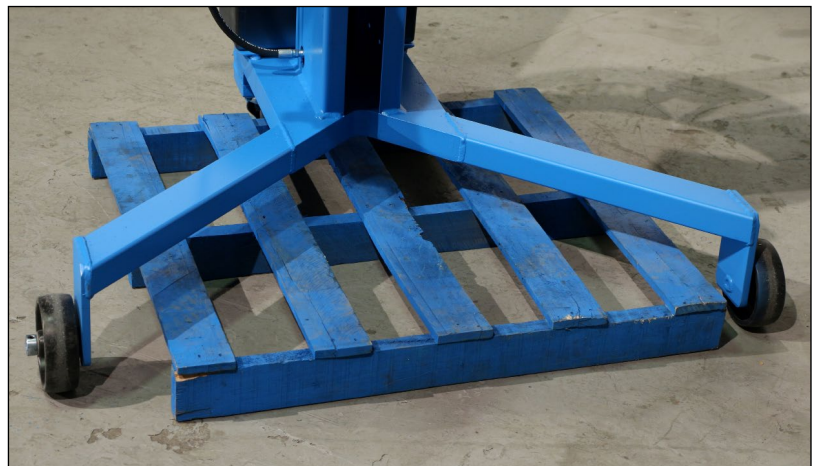

Straddle a pallet up to 41" (104 cm) wide and 7" (17.8 cm) tall

**Dimensions**

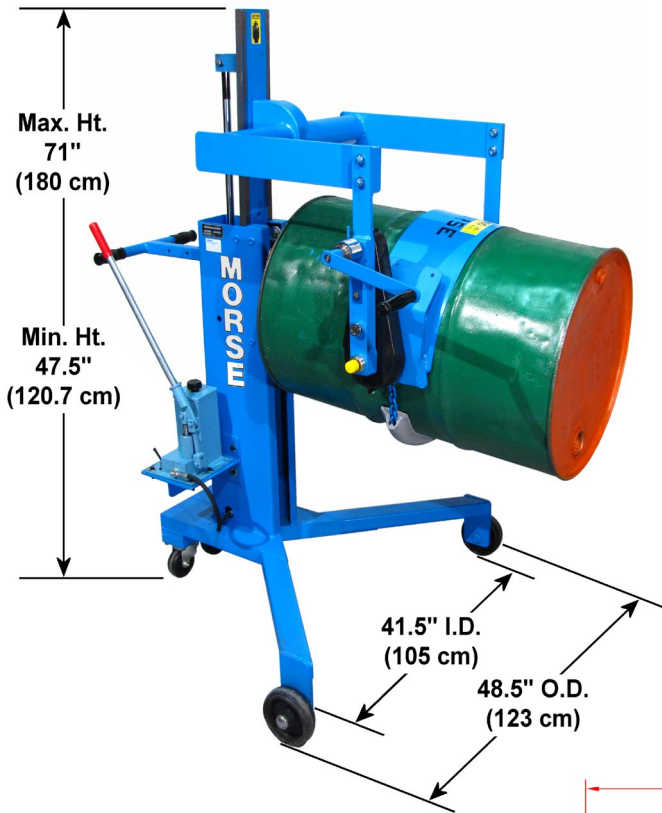

- Overall width: 48.5" (123.2 cm), Overall length: 43" (109.2 cm)
- Turning radius: 53" (135 cm)
- Legs are 9" (22.9 cm) high and reach 20.75" (52.7 cm) in front of upright stanchion
- (2) 4" (10.2 cm) swivel casters at back
- (2) 6" (15.2 cm) wheels at front
- Horizontal 55-gallon drum reaches 18.5" (47 cm) beyond the front wheels of the V-shaped base
- Reach onto pallet up to 20" (50.8 cm) high
- Lift upright 55-gallon drum up to 20" (50.8 cm) from floor. Heavy duty hydraulic lift cylinders include a velocity fuse to provide a full line shut-off in the event of a line failure.
- Maximum dispensing height: 26" (66 cm) for horizontal drum
- Capacity: 600 Lb. (272 kg)

**MADE  
IN  
USA**

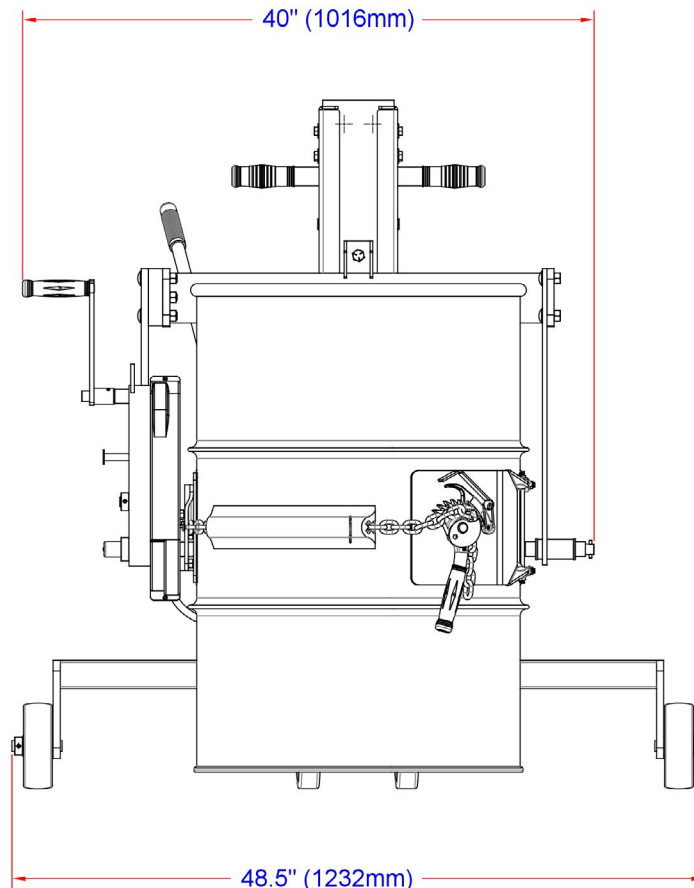

### Optional Kit with Jaws

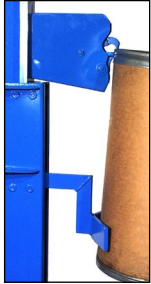

#### Optional Kit to Move Upright Drums Only

Install **kit # 4724-P** to permanently convert 82A-GT Series to an [82H Drum Palletizer](#) for moving and palletizing an upright drum only. It grips the upper drum rim with jaws, while bracing the side, and has no tilt function.

### Recommended MORStop Tilt-Brake

Add factory installed **Option # 3900i-P MORStop Tilt-Brake** to automatically lock and hold the drum tilt angle, until you turn the hand crank again... even if drum contents shift.

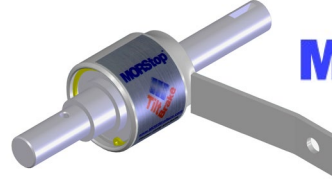

MADE  
IN  
USA

### Options to Handle Various Drums

The 82A-GT Series are designed to handle a ribbed 55-gallon (210 liter) steel drum. They also accept the options below for handling other types and sizes of drum.

#### Kit # 4560B-P

##### Top Rim Clamp

to handle a 55-gallon (210 liter) rimmed plastic or fiber drum. It grips the upper rim of your drum to prevent it from slipping through the drum holder. To handle a 55-gallon plastic drum with top rim, you must install either the Bracket Assembly or the Top Rim Clamp.



#### Kit # 4556-P

##### Bracket Assembly

is required to handle a rimless plastic drum, and recommended to more securely handle a fiber drum. It provides a brace at top and bottom of your drum to prevent it from slipping length-ways through the drum holder. It adjusts for a 31" to 39" (78.7 to 99 cm) tall drum.



#### Diameter Adaptors

Install the correct size [Diameter Adaptors](#) to handle each smaller drum. They install easily inside the drum holder without tools, and are quickly removed.

Diameter Adaptors for 19" (48.3 cm) diameter or larger drum can be used in combination

with the Bracket Assembly. Diameter Adaptors for 17.5" (44.5 cm) diameter or smaller have integrated brackets at top and bottom of the drum that adjust for a drum up to 38" (96.5 cm) tall.

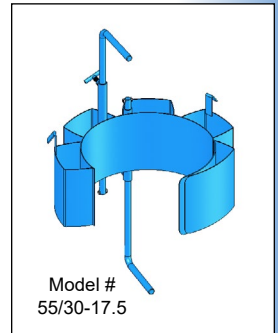

Model 82A-GT-125 shown with

- Kit # 4560B-P Top Rim Clamp
- Factory installed Option # 3900i-P MORStop Tilt-Brake



Model 82A-GT-125 shown with

- Kit # 4556-P Bracket Assembly
- Factory installed Option # 3900i-P MORStop Tilt-Brake



Model 82A-GT-125 shown with

Diameter Adaptor Model # 55/30-17.5

factory installed Option # 3900i-P MORStop Tilt-Brake

**Steps For Use of Morse Drum Palletizers / Movers / Pourers**



1. Roll the Drum Palletizer to your drum with drum holder open and positioned to engage between the drum ribs.
2. Tighten the Top Rim Clamp or adjust the Bracket Assembly height, if your drum palletizer is so equipped.
3. Secure your drum in the drum holder: Drape the cinch chain with flexible chain cover across the front of the drum, insert one chain link into the slot on the ratchet handle, and turn the ratchet handle clockwise to tighten the cinch chain around the drum.



4. Lift your drum from the floor or from a pallet to pouring height by operating the powered lift control or the hand pump.



5. Turn the hand crank to rotate your drum into dispensing position. We recommend the [MORStop Tilt-Brake Option](#) to automatically hold the tilt angle, until you turn the hand crank again.
6. Return your drum to upright position and lower it to the floor or onto a pallet.
7. To remove your drum, release the ratchet handle and open the drum holder.
8. Move onto next drum.

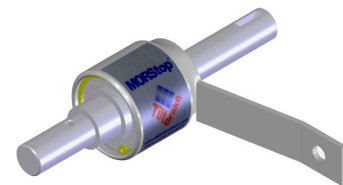

**MORStop** 

MADE  
IN  
USA

### Manual Lift Model

### Ergonomic Power Lift Models

#### Manual Lift Model # 82A-GT

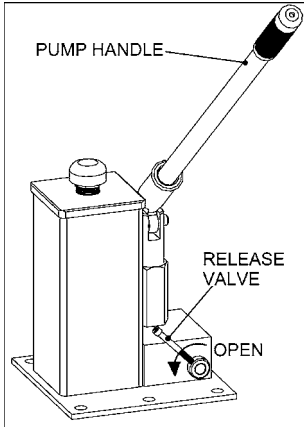

#### Hand Pump Lift Control Model 82A-GT

It takes 27 pumps of the hand pump to lift a drum to maximum height.

#### AC Power Lift Model # 82A-GT-120

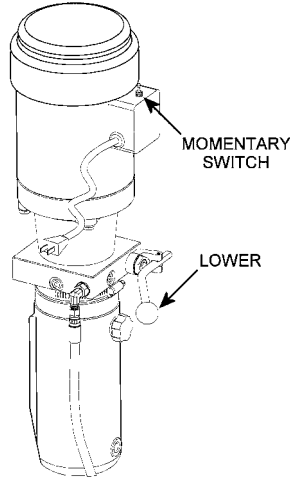

#### Electric Power Lift Control Model 82A-GT-120

Use switch to raise the drum. Lower the drum with manual release valve.

#### Air Power Lift Model # 82A-GT-124

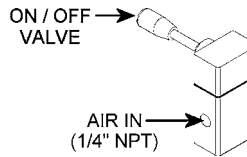

#### Air Power Lift Control Model 82A-GT-124

Use on / off valve to raise and lower the drum.

#### Battery Power Lift Model # 82A-GT-125

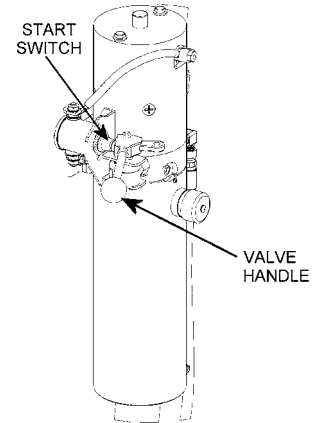

#### Battery Power Lift Control Model 82A-GT-125

Self contained battery power-lift. Use valve to raise and lower the drum. 12V deep cycle battery and separate charger are included.

MADE  
IN  
USA

Model #	Drum Palletizer / Pouter Description	Motor	Domestic Ship Wt *	Options Accepted				
				MORStop Tilt-Brake	Top Rim Clamp	Bracket Assembly	Diameter Adaptors	Kit to Convert to 82H
82A-GT	Hand Crank Geared Tilt	-	534 Lb. (242 kg)	3900i-P	4560B-P	4556-P	55/30 Series	4724-P
82A-GT-120	Hand Crank Geared Tilt, AC Power Lift	1PH/115V/60Hz, TEFC	555 Lb. (252 kg)	3900i-P	4560B-P	4556-P	55/30 Series	4724-P
82A-GT-124	Hand Crank Geared Tilt, Air Power Lift	-	525 Lb. (239 kg)	3900i-P	4560B-P	4556-P	55/30 Series	4724-P
82A-GT-125	Hand Crank Geared Tilt, DC Power Lift	12V DC Motor **	581 Lb. (264 kg)	3900i-P	4560B-P	4556-P	55/30 Series	4724-P
82AM-GT	Hand Crank Geared Tilt with spark resistant parts	-	540 Lb. (242 kg)	3900i-P	4560M-P	4556M-P	55/30M Series	4724M-P
82AM-GT-124	Hand Crank Geared Tilt, Air Power Lift with spark resistant parts	-	525 Lb. (239 kg)	3900i-P	4560M-P	4556M-P	55/30M Series	4724M-P

\* Domestic Ship Dimensions: L50" W50" H56" (127 x 127 x 142 cm)

\*\* 12V DC Power Lift includes battery, and 100/220V 50/60Hz AC charger.

NOTE: 12V Deep Cycle Lead Acid Battery is designed for domestic shipment only. For export shipment, choose the following battery option:

- Option "NB" No Battery. Customer must obtain battery before use... Exide # 27MDP 12V Deep Cycle Battery or equivalent.