

CONTENTS

- **Receiving Procedures**
- **Warranty**
- **Safety Information**
- **Description**
- **Assembly Instructions**
- **Maintenance**
- **Parts List and Diagram**



Receiving Procedures

Every Morse drum handler is inspected prior to shipping. However, damage may be incurred during transit.

- Check for visible damage. If you choose to accept damaged freight, always sign noting the damage on the **BILL OF LADING**.
- Document the damage and have the truck driver sign. We recommend keeping a digital camera at your receiving dock for this purpose.
- Open packages expeditiously to check the condition of the goods. There is only a 24 hour window to notify the carrier of any concealed damage.
- **IMMEDIATELY REPORT ALL DAMAGE TO THE SHIPPING COMPANY!** Then you may contact Morse for assistance with your freight claim.
- Morse Manufacturing will not be held responsible for any damaged freight that is not signed for as damaged.

Delivery to non-business addresses without a loading dock result in additional freight charges. Residential delivery fees, inside delivery fees, re-delivery charges, and lift gate services will be added by the truck line, and are non-negotiable.

Limited 2 Year Warranty

Morse drum handling equipment is guaranteed against defects in workmanship or materials for **TWO YEARS** when used properly within its rated capacity. Warranty does not cover wear from normal use or damage from accident or abuse. Motors and other purchased parts carry the warranties of their manufacturers.

For warranty claims, contact your Morse Dealer to obtain a return authorization number, and for return freight advice. Return freight must be prepaid.

In all instances, liability is limited to the purchase price paid or to repairing or replacing the product. Customer assumes liability for any modifications, unauthorized repairs or parts substitution.

Safety Information

While Morse Manufacturing Co. drum handling equipment is engineered for safety and efficiency, a high degree of responsibility must be placed upon the machine operator to follow safe practices, based primarily on common sense, upon which true safety depends.

Failure to follow the safety precautions in this manual can result in personal injury or property damage. Observe the same precautions as with similar machinery where carelessness in operating or maintenance is hazardous to personnel. Carefully read the safety precautions below and throughout this manual.

Review the Material Safety Data Sheet(s) for the material(s) in the drum(s) and take all necessary precautions. Safety shoes, work gloves, hard hat and other personal protective devices are recommended.

Prior to initial use, inspect all moving parts. Perform necessary load test, inspections, operator training, etc.



DANGER - Indicates a situation which, if not avoided, will result in serious injury or death. This signal word is limited to the most extreme situations.



WARNING - Indicates a situation which, if not avoided, could result in serious injury or death.



CAUTION - Indicates a situation which, if not avoided, can result in damage to the machine.

	WARNING - DO NOT make alterations or modify the unit. Under no circumstances should any modifications be made to the Morse machinery without factory authorization. Any modifications may void the warranty. This machine was designed to perform a specific job and alterations may result in injury to operator or machine.
	WARNING - DO NOT exceed the weight capacity of 75 Lb. (34 kg).
	WARNING - DO NOT operate damaged or malfunctioning unit, or a unit with missing parts.
	WARNING - DO NOT operate without first having read and understood operating manual.
	WARNING – No Loose Fitting Clothing. Wear close-fitting clothing and safety equipment appropriate to the job. Loose fitting clothing may become caught on the machinery and cause severe personal injury.
	WARNING - Wear safety shoes with non-slip soles and hard toe protection.
	WARNING - This product can expose you to chemicals including barium sulfate, cobalt, titanium dioxide, and 2-methylimidazole, which are known to the State of California to cause cancer, and bisphenol-A, which is known to the State of California to cause birth defects or other reproductive harm. For more information go to www.P65Warnings.ca.gov

Description

Model 15-SS Can Tipper is designed to dispense a 5-gallon (19 liter) steel or plastic can or pail up to 12.25" (31.2 cm) in diameter and 10" to 19" (25.4 to 48.3 cm) tall.

The maximum capacity is 75 Lb. (34 kg).



Assembly Instructions

1. Unpack and identify the following parts:
 - 1 - Base Assembly
 - 1 - Can Holder with Catch
 - 1 - Center Brace
 - 6 - 1/4-20 x 5/8 Panhead Screws
 - 6 - 1/4-20 Two Way Lock Nuts
2. Spread base assembly open, hinging at base riveted joints.
3. Fasten center brace in place using four screws and nuts as shown with brace top inside uprights, and fasten brace bottom outside frame. Tighten securely.
4. Rotate can holder ring to horizontal position, hinging at holder riveted joint, with catch upright as shown.
5. Place can holder between uprights of base. Insert screws (from inside of ring) through holes in can holder ring and through base uprights. Thread nuts onto bolts but do not tighten completely. Nuts should be just loose enough to allow can holder to pivot freely.
6. Place a few drops of oil on pivot bolts before using and reapply oil periodically to minimize wear.

Maintenance

Periodically inspect all moving parts, framework, and contact areas for signs of wear, fatigue, or loosening.

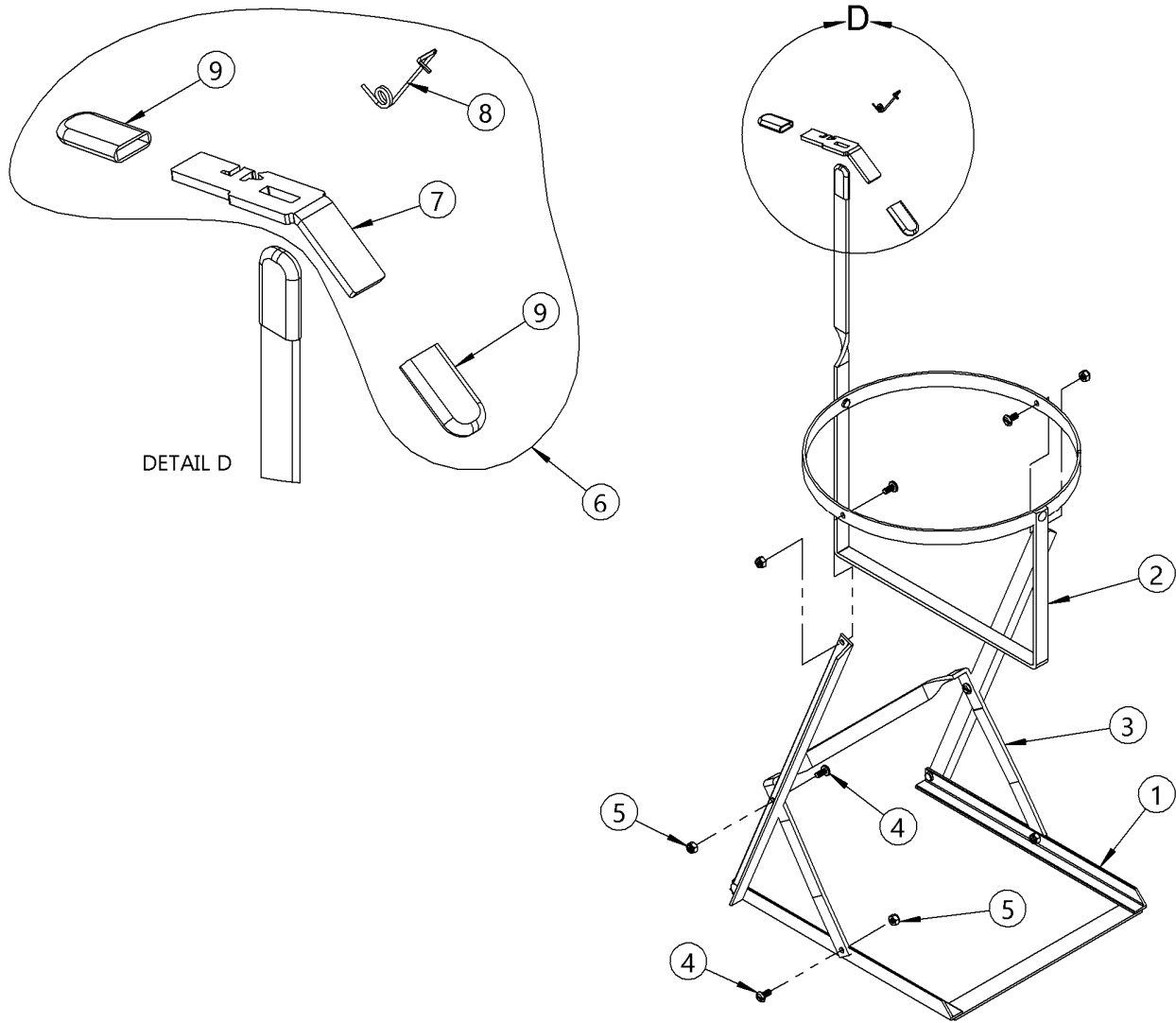

ITEM	QTY.	PART #	DESCRIPTION
1	1	4277SS-P	BASE ASSEMBLY, 15-SS
2	1	2713-P	CAN HOLDER ASSEMBLY, 15-SS
3	1	4281SS-P	CENTER BRACE, 15-SS
4	6	1517SS-P	SCREW, 1/4-20 X 5/8 PAN HD, SS
5	6	1518SS-P	NUT, 1/4-20 NYLON LOCK, SS
6	1	6799SS-P	CATCH ASSEMBLY, 15-SS WITH SPRING
7	1	6800SS-P	CATCH PIECE, 15-SS
8	1	6801-P	SPRING, SS, CATCH ASSEMBLY, 15
9	2	4234-P	CAP, PLASTIC, HANDLE, CATCH 15