

## CONTENTS

- Assembly Instructions
- Parts List and Diagram

## Model 160-SS

Stainless Steel 4-Wheel Drum Truck

Wheels inside frame

Capacity: 1000 Lb. (454 kg)



## Assembly Instructions

1. Insert Hook Weld (item 7) into tube of drum truck base with holes aligned.
2. Install handle onto drum truck base. Secure with 2 screws (item 11) using 7/32" hex wrench.

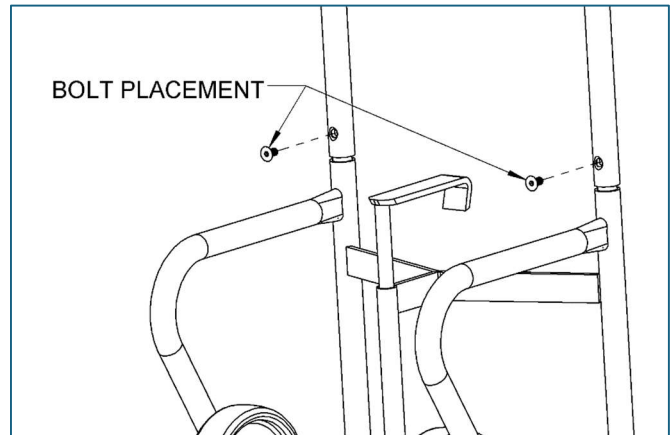

**WARNING** - This product can expose you to chemicals including barium sulfate, cobalt, titanium dioxide, and 2-methylimidazole, which are known to the State of California to cause cancer, and bisphenol-A, which is known to the State of California to cause birth defects or other reproductive harm. For more information go to [www.P65Warnings.ca.gov](http://www.P65Warnings.ca.gov)



ITEM NO.	PART NUMBER	DESCRIPTION	QTY.
3	4685SS-P	SHCS, 3/8-16 X 3/4 FH, SS	2
4	2752-P	STAND WELD, 160-SS	1
5	2758-P	AXLE, 19.75", 160-SS	2
6	87-P	WHEEL, MORTUF, 8", 3/4" BRG	4
7	55SS-P	WASHER, 3/4 SAE FL 1-1/2 OD SS	4
8	15SS-P	COLLAR, 3/4" ID, SS	4
9	1114SS-P	SPRING, EXTENSION, SS, 160-SS	1
10	5941SS-P	HOOK WELD, 160-SS	1
11	1000SS-P	SET SCREW, 1/4-20 X 3/8, SS	4