

Parts List and Diagram for Part # 400-96SS Base Assembly
Used on Morse 400 Series 96" Stainless Steel Hydra-Lift Karriers
Serial # 0820 to ____ (MMYY)

400-96SS

IMPORTANT NOTE

4-Digit serial numbers are simply the month & year of manufacture

Example: 0802 is August 2002

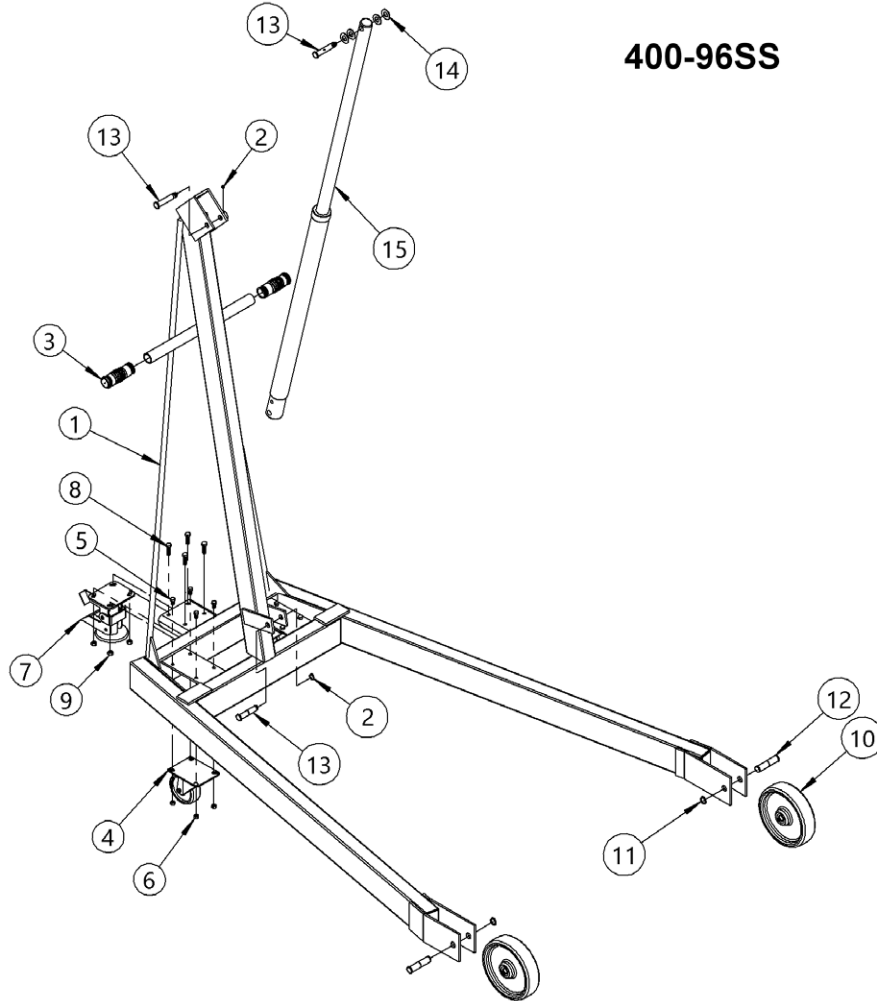

ITEM NO.	PART NUMBER	DESCRIPTION	QTY.
1	6099SS-P	TOWER ASM, 400A-96SS	1
2	1005-P	SET SCREW, 5/16-18 X 3/8 KNURL	2
3	83-P	GRIP, HANDLE, 1-1/4 X 4-1/2	2
4	3308SS-P	CASTER, 4" SWIVEL, SS	2
5	215SS-P	HHCS, 5/16-18 X 5/8, SS	8
6	3920SS-P	NUT, 5/16-18 NYLON LOCK, SS	8
7	2386-P	FLOOR LOCK, STEP DOWN 5-3/4"	1
8	535SS-P	HHCS, 3/8-16 X 1-1/4, SS	4
9	3981SS-P	NUT, 3/8-16 NYLON LOCK, SS	4
10	87-P	WHEEL, MORTUF, 8", 3/4" BRG	2
11	5330SS-P	SNAP RING, EXT, SS, 3/4"	2
12	5329SS-P	PIN, GROOVE, 3/4 X 3.10 SS	2
13	6061SS-P	PIN, CLEVIS, 400SS, GREASE FIT	3
14	17SS-P	WASHER, 5/8 SAE 1-5/16 OD, SS	4
15	3006-P	CYLINDER, 1.5 X 29, 510 515 610	1