

### Drum Movers and Palletizers



Model 82A-125 shown has battery power drum lift

### Move, Palletize and Dispense Drum



### Accessories for Various Drums

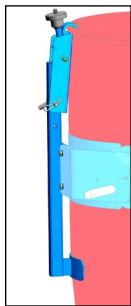

Install **Top Rim Clamp Kit** to safely handle a 55-gallon RIMMED plastic or fiber drum. It grips the upper rim of drum to prevent it from slipping length-ways in the drum holder. To handle a 55-gallon (210 liter) plastic or fiber drum with top rim, you must install either the Bracket Assembly or the Top Rim Clamp.

**Kit # 4560-P** Top Rim Clamp

**Kit # 4560SS-P** Stainless Steel Top Rim Clamp with bead blast finish

Install **Bracket Assembly Kit** required to safely handle a RIMLESS plastic or fiber drum. The braces at top and bottom of the drum to prevent it from slipping length-ways in the drum holder. The bracket adjusts for a 31" to 39" (79 to 99 cm) tall drum.

**Kit # 4556-P** Bracket Assembly

**Kit # 4556SS-P** Stainless Steel Bracket Assembly with bead blast finish

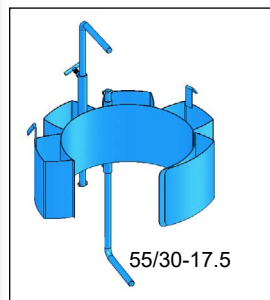

Install a **Diameter Adapter** to handle a smaller drum. They install easily inside the drum holder without tools, and are quickly removed. Choose the correct size to for each size of smaller drum.

Diameter Adapters for 19" (48 cm) diameter or larger drum can be used in combination with the Bracket Assembly. Diameter Adapters for 17.5" diameter or smaller have integrated brackets at top and bottom of the drum that adjust for a drum up to 38" (96.5 cm) tall.

Stainless Steel Diameter Adapters are available with bead blast finish

This innovative design combines the V-shaped base to serve the corner of a pallet, with a drum holder to rotate and dispense a drum.

- Models with AC, DC or Air power lift
- Lift, Transport and dispense a drum up to 600 Lb. (272 kg)
- Secure drum in holder with web strap
- Use Tilt Locks to lock at horizontal for dispensing. Lock upright to prevent spills while transporting.

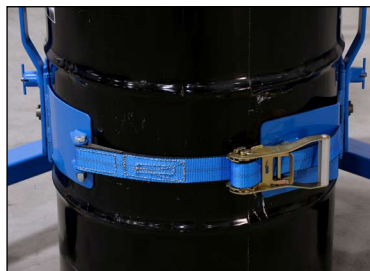

- Lift 55-gallon (210 liter) steel drum up to 20" (50.8 cm) above floor in upright position. Heavy-duty hydraulic lift cylinder includes velocity fuse to provide a full line shut-off in the event of a line failure.
- Grab drum by hand to rotate drum for pouring
- Dispense horizontal drum up to 26" (66 cm) high
- Horizontal 55-gallon (210 liter) steel drum reaches 18.5" (47 cm) beyond front wheels
- V-Shaped base to service pallet corner. Counterweighted for stability.
- Service spill containment pallet up to 20" (50.8 cm) high

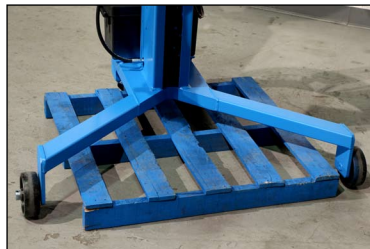

### Manual Lift Models

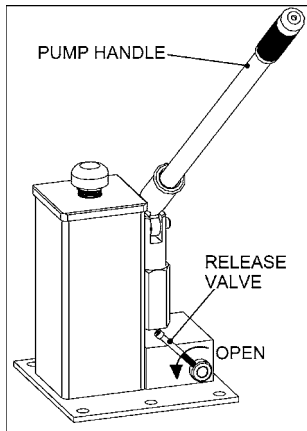

#### Hand Pump Lift Control Models 82A and 82A-SS

It takes 27 pumps of the hand pump to lift a drum to maximum height.

### Ergonomic Power Lift Models

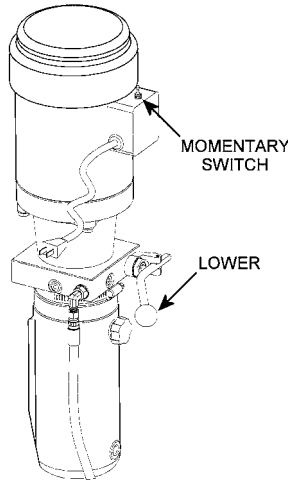

#### Electric Power Lift Controls Models 82A-120 and 82A-SS-125

Use switch to raise the drum. Lower the drum with manual release valve.

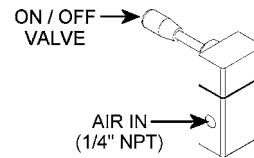

#### Air Power Lift Controls Model 82A-124 and 82A-SS-124

Use on / off valve to raise and lower the drum.

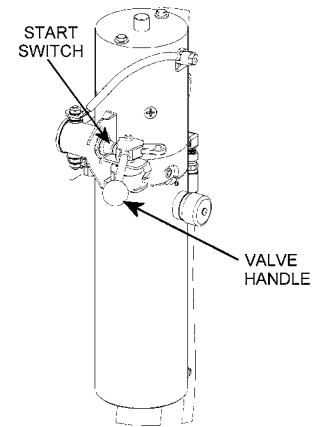

#### Battery Power Lift Controls Model 82A-125 and 82A-SS-125

Self contained battery power-lift. Use valve to raise and lower the drum. 12V deep cycle battery and separate charger are included.

Model #	Drum Palletizer / Pouter Description	Motor	Options & Accessories			Kit to Permanently Convert to 82H
			Top Rim Clamp Kit	Bracket Assembly Kit	Diameter Adapters	
82A	Hand Pump Drum Lift	-	4560-P	4556-P	55/30 Series	4724-P
82A-120	60Hz AC Power Drum Lift	1 HP, Single-phase, 115V, 60Hz, TEFC	4560-P	4556-P	55/30 Series	4724-P
82A-124	Air Power Drum Lift	-	4560-P	4556-P	55/30 Series	4724-P
82A-125	Battery Power Drum Lift *	12V DC Motor *	4560-P	4556-P	55/30 Series	4724-P
82A-127	50Hz AC Power Drum Lift	1 HP, Single-Phase, 110/220V, 50Hz	4560-P	4556-P	55/30 Series	4724-P
<b>Stainless Steel Models - Frame made of Type 304 Stainless Steel with Bead Blast Finish</b>						
82A-SS	Hand Pump Drum Lift	-	4560SS-P	4556SS-P	55/30SS Series	-
82A-SS-120	60Hz AC Power Drum Lift	1 HP, Single-phase, 115V, 60Hz, TEFC	4560SS-P	4556SS-P	55/30SS Series	-
82A-SS-124	Air Power Drum Lift	-	4560SS-P	4556SS-P	55/30SS Series	-
82A-SS-125	Battery Power Drum Lift *	12V DC Motor *	4560SS-P	4556SS-P	55/30SS Series	-

\* Includes 12V DC battery and 100/220V 50/60Hz AC charger. 12V Deep Cycle Lead Acid Battery is designed for domestic shipment only. For export shipment, add Option "NB" No Battery. Customer must obtain battery before use... Exide # 27MDP 12V Deep Cycle Battery or equivalent.

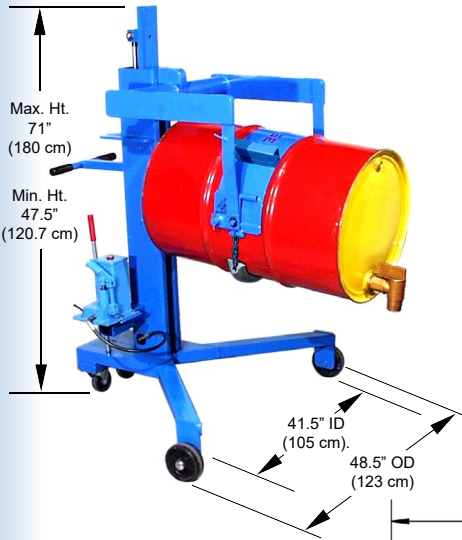

### Dimensions of 82A Series

- Overall width: 48.5" (123.2 cm)
- Overall length: 43" (109.2 cm)
- Turning radius: 53" (135 cm)
- Legs are 9" (22.9 cm) high and reach 20.75" (52.7 cm) in front of upright stanchion
- (2) 4" (10.2 cm) swivel casters at back
- (2) 6" (15.2 cm) wheels at front

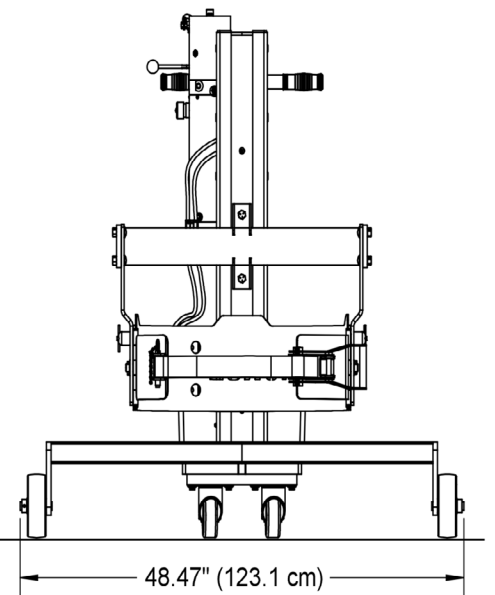
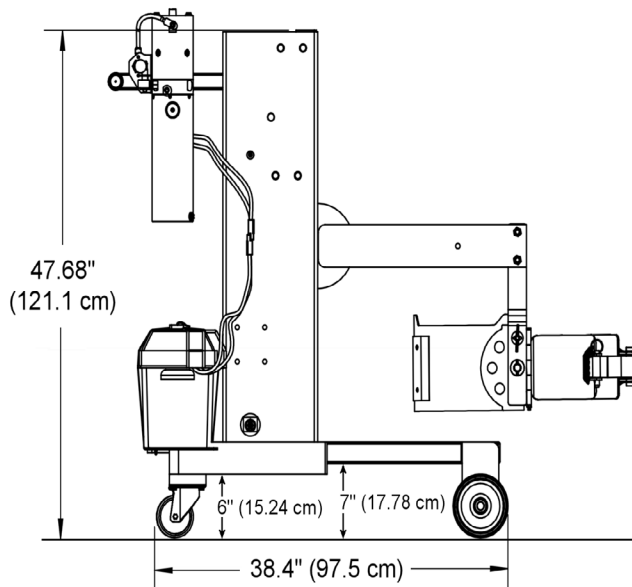
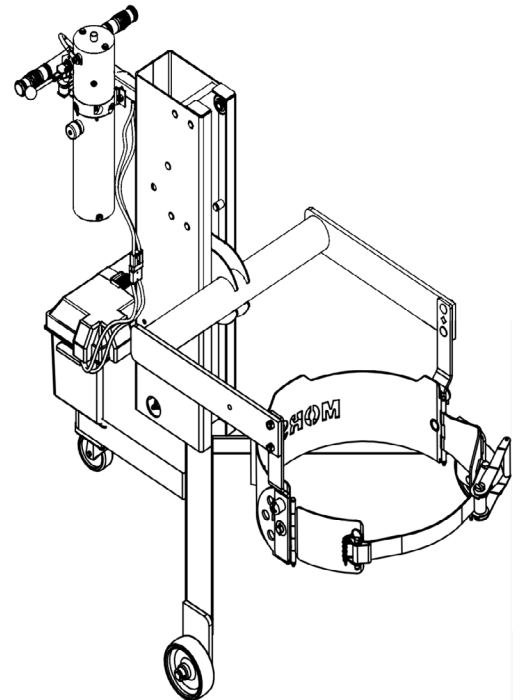
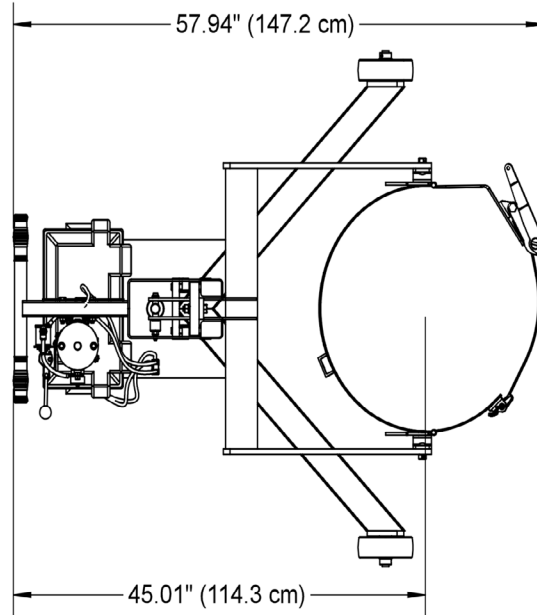

**Other Models Available**



**Drum Palletizers  
with Hand Crank Geared Tilt**

Model # 82A-GT adds hand crank geared drum tilt to control pouring to the drum mover / pourer / palletizer. It is shown here with optional [MORStop Tilt-Brake](#) which automatically stops and holds the drum tilt angle.

Models are available with hand crank geared drum tilt and battery, electric or air power drum lift.

See full details on the [82A-GT Spec Sheet](#)

**Kit # 4724-P to Permanently  
Convert an 82A to 82H**

- 82H Series Move UPRIGHT Drum
- Jaws Grip Top Rim of Drum

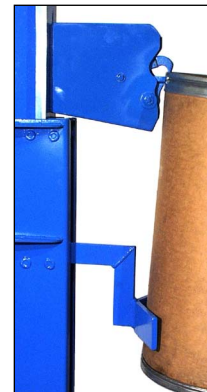

Install Kit # 4724-P for **ONE-TIME conversion** to 82H Drum Palletizer to move and palletize an upright drum only. 82H Series grip the upper drum rim with jaws, while bracing the drum side.

82H Series have **NO TILT** function.