

**Tilt-To-Load Drum Tumblers Feature Power-Tilt to Enable Easy, Floor-Level Loading**



- Rotate closed plastic, steel, or fiber drum
- Thorough corner-over-corner mixing action
- Save time, labor and money
- Use a separate drum for each batch
- No container to purge between batches

**Mixing in a Closed Drum Means Less Hazards**

Using a Morse Drum Rotator eliminates spills, splashing of dangerous contents on workers, and risk of contamination. Now you can get the benefits of mixing inside closed shipping drums and have the machine do the work of loading and unloading itself! Morse 310 Series models accept the drum upright at floor level. The user controls hydraulic tilting action that raises the drum into position for rotating. A second valve allows the operator to start and stop the hydraulic motor that drives rotation. You minimize time, labor and operating cost by eliminating extra moves required for getting drum into mixing position. Rotate various sized drums, weighing up to 800 Lb. (363 kg) at 5 to 20 RPM.

Install all Morse Rotators in accordance with OSHA requirements for [enclosure and safety interlock](#), etc. so the rotator automatically turns off when enclosure door is opened. One way to accomplish this is with a Morse enclosure with safety interlock.

MADE  
IN  
USA

**Tilt-To-Load Drum Tumblers**

- Tumble a plastic, steel or fiber drum:
  - 29" to 37" (74 to 94 cm) tall
  - 18" to 23.5" (46 to 60 cm) in diameter
- Rotate your drum at:
  - 5 to 20 RPM for 60Hz AC models
  - 4 to 16 RPM for 50Hz AC models
  - 5 to 12 RPM for Air model
- Capacity:
  - 800 Lb. (363 kg) Full Drum
  - 400 Lb. (181 kg) Half-Full Drum

Half-full Capacity is an indication of the capacity for tilting an unbalanced, bottom-heavy drum. A partially full drum with an unbalanced and shifting load is harder to tilt than a full drum.



Tilt-To-Load Drum Tumbler shown with Controls and Enclosure with Safety Interlock (sold separately)

OSHA compliance, see OSHA subpart O.1910.212(a)(4) "Barrels, containers, and drums. Revolving drums, barrels, containers shall be guarded by an enclosure which is interlocked with drive mechanism, so that barrel, drum, or container cannot revolve unless the guard enclosure is in place."

Power connections and motor controls must comply with applicable codes.

**Optional Hydraulic Oil Cooler** for applications requiring a higher service factor, such as longer run times or operating in areas with high ambient temperature.

- Factory Installed Option # 5014i-P on AC model
- Kit # 5014KIT-P for customer to install on AC model

**1. Load Upright Drum with Floor Level**



Load drum into lowered drum holder with hinged ratchet plate and the top clamps both open. [Model 152 Drum Truck](#) is shown loading drum. Can also load with [Model 81 Drum Spotter](#) or [Model 92 Below-Hook Drum Lifter](#).

**2. Secure Drum in Holder**



Secure drum in the rotator using the web strap and ratchet, and tightening the top clamps (inset).

**3. Power Lift and Rotate**



Turn the motor on to activate the hydraulics. Raise the drum to the top position by raising the TILT control valve. To begin rotating, raise the ROTATE control valve.

**Dimensions**

**Loading Position**

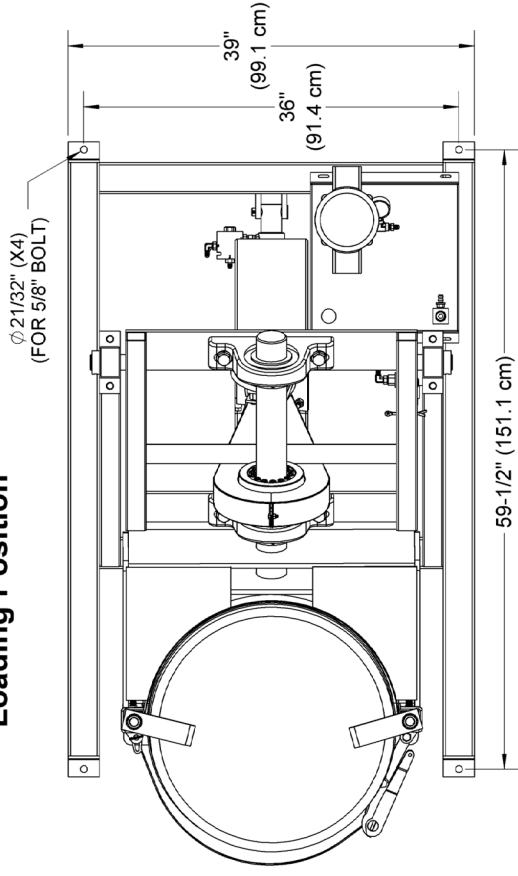

**Rotating Position**

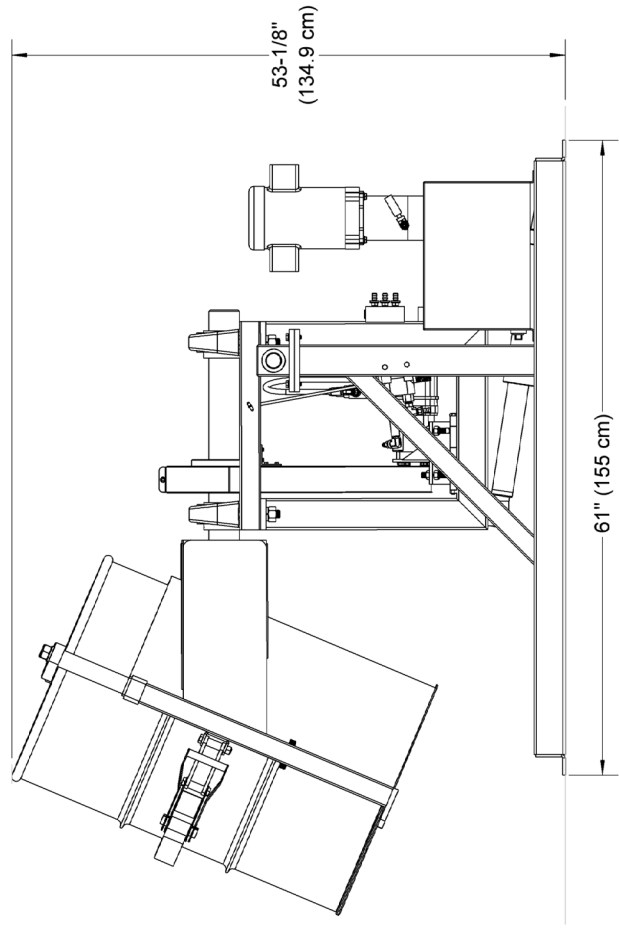
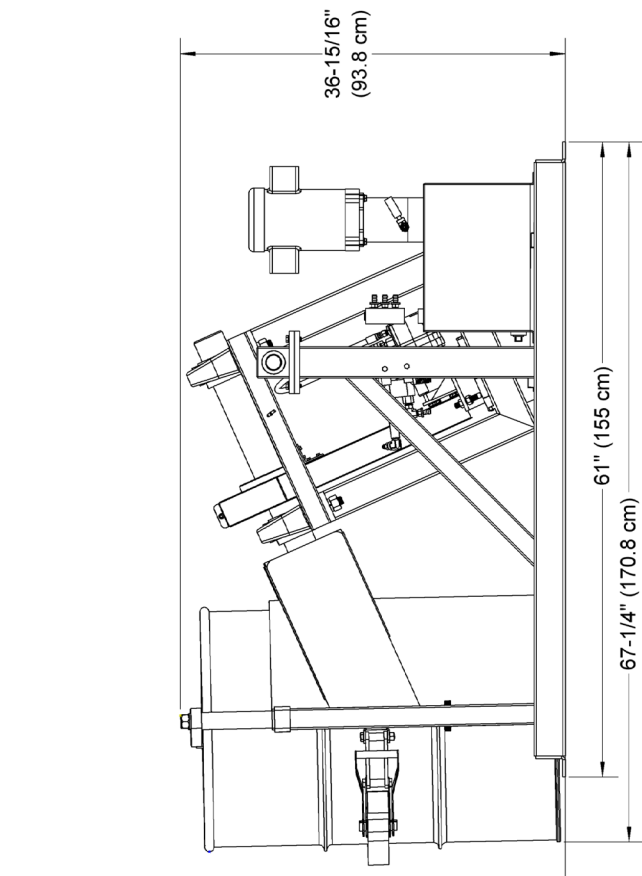
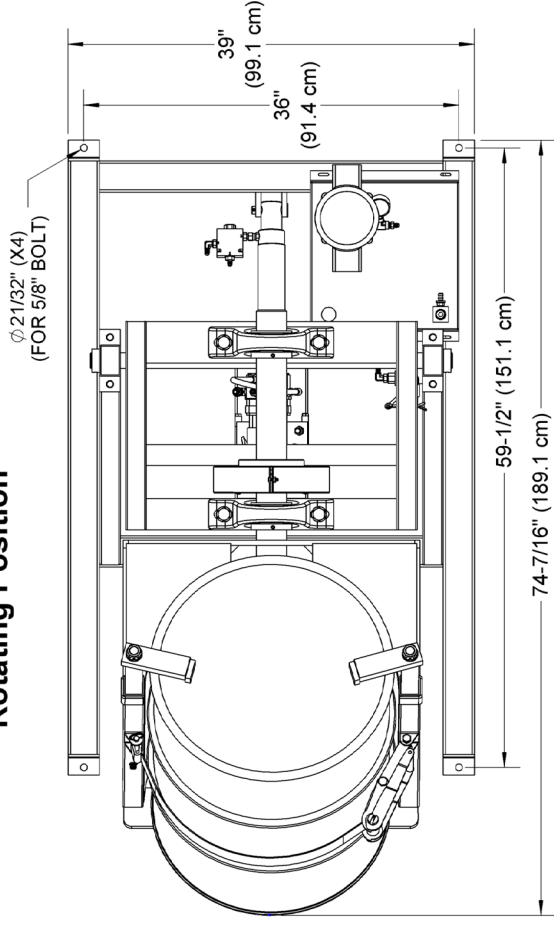

DRUM HOLDER (PART # 5801-P)  
SHOWN WITH CLAMPS AT HIGHEST POSITION

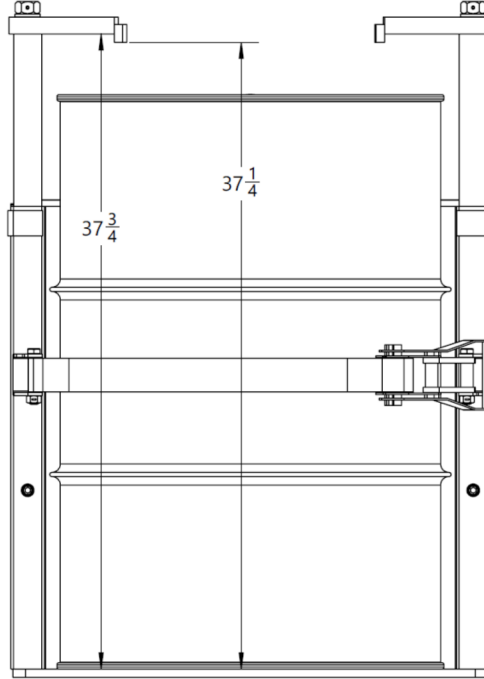

MADE  
IN  
USA

Tilt-To-Load Drum Tumblers							Control Packages See Page 3	Guard Enclosure Kits See Page 4
Model #	Drum RPM (22.5" Dia.)	Motor Information					Option #	Kit #
		Motor Style	HP	Phase	Motor Voltage	Amp Draw		
310-1	5 to 20	60 Hz TEFC	2	1	115	23 †	CP-310-1-115 *	GEK-310-1
					208	12	CP-310-1-230 *	
					230	11.5		
310-3	5 to 20	60Hz TEFC	2	3	208	5.3	CP-310-3-230 *	GEK-310-3
					230	5.0		
					460	2.5	CP-310-3-460 *	
310-3-575	5 to 20	60Hz TEFC	2	3	575	2.0	CP-310-3-575 *	GEK-310-3
310-E1	5 to 20	60Hz Explosion proof **	2	1	115	21 †	CP-310-E1-115 *	GEK-310-E1
					208	11.5	CP-310-E1-208 *	
					230	10.5	CP-310-E1-230 *	
310-E3	5 to 20	60Hz Explosion proof **	2	3	208	5.3	CP-310-E3-208 *	GEK-310-E3
					230	5.0	CP-310-E3-230 *	
					460	2.5	CP-310-E3-460 *	
310-A	5 to 12	Air Motor ***	-	-	-	-	Air Controls are included with model 310-A ***	GEK-310-A
<b>Models for Countries with 50Hz Power Supply</b>								
310-1-50	4 to 16	50Hz TEFC	2	1	220	9.7	CP-310-1-220-50 *	GEK-310-1
310-3-50	4 to 16	50Hz TEFC	2	3	230	5.0	CP-310-3-230-50 *	GEK-310-3
					400	2.9	CP-310-3-400-50 *	
310-E1-50	4 to 16	50Hz Explosion proof **	2	1	220	9.8	CP-310-E1-220-50 *	GEK-310-E1
310-E3-50	4 to 16	50Hz Explosion proof **	2	3	230	5.5	CP-310-E3-230-50 *	GEK-310-E3
					400	3.2	CP-310-E3-400-50 *	

\* ONLY NON-Explosion Proof AC Control Packages include a pre-wired control box. Explosion-proof Control Packages have no wiring from the NEMA 7/9 control box to the motor. Please consult an electrician to complete the wiring in accordance to local code.

\*\* Explosion-proof motors are rated for Class I Group D, and Class II Groups F and G.

\*\*\* Air powered model requires plant air at 50 to 60 PSI and flowing at a rate of 60 SCFM. Filter, Regulator, Lubricator and valve are included with drum Tumbler model 310-A.

† Requires 30 Amp circuit, and can have amp spikes higher than that.

Crates for Export	
Export Crate #	Description
3212X-P	Fully Enclosed Crate for Export of (1) Tilt-To-Load Drum Tumbler
4463X-P	Fully Enclosed Crate for Export of (1) Guard Enclosure Kit
5480X-P	Fully Enclosed Crate for Export of (1) Tilt-To-Load Drum Tumbler, (1) Control Package and (1) Guard Enclosure Kit

MADE  
IN  
USA

**Control Packages (sold separately)**

Select the appropriate Control Package for each model, and your power supply. Use power controls to start and stop drum rolling. The control mast can be positioned outside the Safety Enclosure on either the left or right side, or at the back of Drum Tumbler.

**AC Control Package (sold separately) NEMA 4/12 for NON-Hazardous Areas**

Includes Control Box with:

- Timer adjusts from a few seconds to 16 hours
- Start and Stop Buttons
- Red Emergency Stop Button
- Lockable Main Disconnect to shut off and lock out power to the unit
- Wire terminals for external connection of safety interlock switch

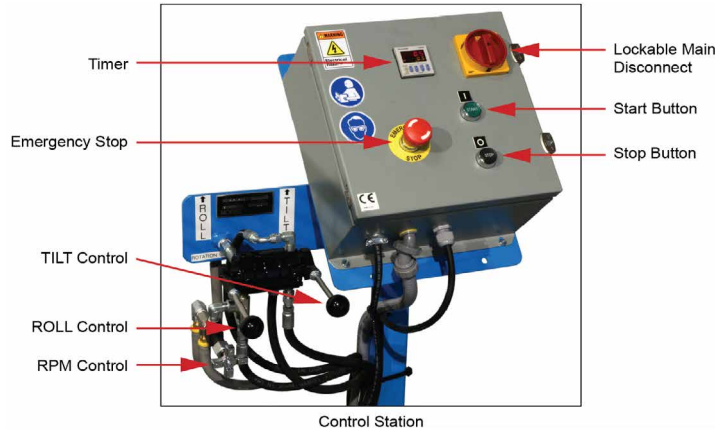

**Explosion Proof AC Control Package (sold separately) NEMA 7/9 for Hazardous Areas**

Includes Control Box with:



- Start and Stop Buttons
- Wire terminals for external connection of safety interlock switch

MADE  
IN  
USA

Control Package #	Description	Minimum Power Supply Required	Power Supply
<b>CP-310-1-115 *</b>	Control Package for 310-1	30 Amp	1-Phase 115V 60Hz
<b>CP-310-1-230 *</b>	Control Package for 310-1	15 Amp	1-Phase 230V 60Hz
<b>CP-310-1-220-50</b>	Control Package for 310-1-50	15 Amp	1-Phase 220V 50Hz
<b>CP-310-3-230 *</b>	Control Package for 310-3	15 Amp	3-Phase 230V 60Hz
<b>CP-310-3-460 *</b>	Control Package for 310-3	10 Amp	3-Phase 460V 60Hz
<b>CP-310-3-230-50</b>	Control Package for 310-3-50	10 Amp	3-Phase 230V 50Hz
<b>CP-310-3-400-50</b>	Control Package for 310-3-50	10 Amp	3-Phase 400V 50Hz
<b>CP-310-3-575</b>	Control Package for 310-3-575	10 Amp	3-Phase 575V 60Hz
<b>CP-310-E1-115 *</b>	Control Package for 310-E1, Explosion-Proof	30 Amp	1-Phase 115V 60Hz
<b>CP-310-E1-208 *</b>	Control Package for 310-E1, Explosion-Proof	15 Amp	1-Phase 208V 60Hz
<b>CP-310-E1-230 *</b>	Control Package for 310-E1, Explosion-Proof	15 Amp	1-Phase 230V 60Hz
<b>CP-310-E1-220-50 *</b>	Control Package for 310-E1-50, Explosion-Proof	15 Amp	1-Phase 220V 50Hz
<b>CP-310-E3-208 *</b>	Control Package for 310-E3, Explosion-Proof	15 Amp	3-Phase 208V 60Hz
<b>CP-310-E3-230 *</b>	Control Package for 310-E3, Explosion-Proof	15 Amp	3-Phase 230V 60Hz
<b>CP-310-E3-230-50 *</b>	Control Package for 310-E3-50, Explosion-Proof	15 Amp	3-Phase 230V 50Hz
<b>CP-310-E3-460 *</b>	Control Package for 310-E3, Explosion-Proof	10 Amp	3-Phase 460V 60Hz
<b>CP-310-E3-400-50 *</b>	Control Package for 310-E3-50, Explosion-Proof	10 Amp	3-Phase 400V 50Hz

**Air Controls are Included with Model 310-A**

**Air Controls Include**

- Filter, Regulator and Lubricator (FRL)
- On / Off Valve



**Guard Enclosure Kits with Safety Interlock (sold separately)**

**Comply with OSHA Requirements with a Morse Guard Enclosure Kit (Sold Separately)**

Guard Enclosures for Morse Tilt-To-Load Drum Tumblers have a safety interlock to automatically shut off the Drum Tumbler when the gate is opened. Open the enclosure gate, place your drum onto the drum Tumbler, then close the gate to allow operation. Connections are included for air powered model only. Morse Control Packages (page 3) provide controls and connections for AC models.

All Morse Control Packages (see page 3) include a low-voltage transformer and wire terminals required to connect the external safety interlock switch of these Guard Enclosure Kits. Morse Control Packages and Enclosures meet OSHA regulations ONLY when installed properly with safety interlock.

Install all Morse Rotators in accordance with local requirements for enclosure and safety interlock, etc. One way to accomplish this is with a Morse enclosure with safety interlock, so the rotator automatically turns off when enclosure door is opened. Power connections and motor controls must also comply with applicable local codes.

For OSHA compliance in the USA, see OSHA subpart O.1910.212(a) (4) "Barrels, containers, and drums. Revolving drums, barrels, and containers shall be guarded by an enclosure which is interlocked with the drive mechanism, so that the barrel, drum, or container cannot revolve unless the guard enclosure is in place."

Guard Enclosure Kit #	Description	Gate Switch
<b>GEK-310-1</b>	Fits Tilt-To-Load Drum Tumbler with 1-phase electric motor	AC
<b>GEK-310-3</b>	Fits Tilt-To-Load Drum Tumbler with 3-phase electric motor	AC
<b>GEK-310-E1</b>	Fits Tilt-To-Load Drum Tumbler with Explosion-proof 1-phase electric motor	AC
<b>GEK-310-E3</b>	Fits Tilt-To-Load Drum Tumbler with Explosion-proof 3-phase electric motor	AC
<b>GEK-310-A</b>	Fits Tilt-To-Load Drum Tumbler with Air motor	Air

MADE  
IN  
USA

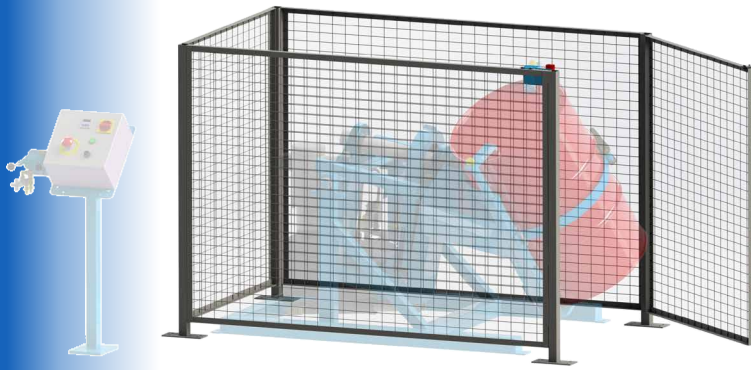

Guard Enclosure with safety interlock (shown with Drum Tumbler and Control Package each sold separately)

**Outside Post-to-Post Dimensions of Enclosures**

L88" x W52" x H63.25" (224 x 132 x 161 cm)

4' (121.9 cm) Wide Hinge Door Opening

