

#### Parts List and Diagram for Morse Part # 410-PL with Serial Number 1210 to \_\_\_\_ (MMYY)



#### IMPORTANT NOTE

4-Digit serial numbers  
are simply the month  
& year of manufacture

Example: 0802 is  
August 2002

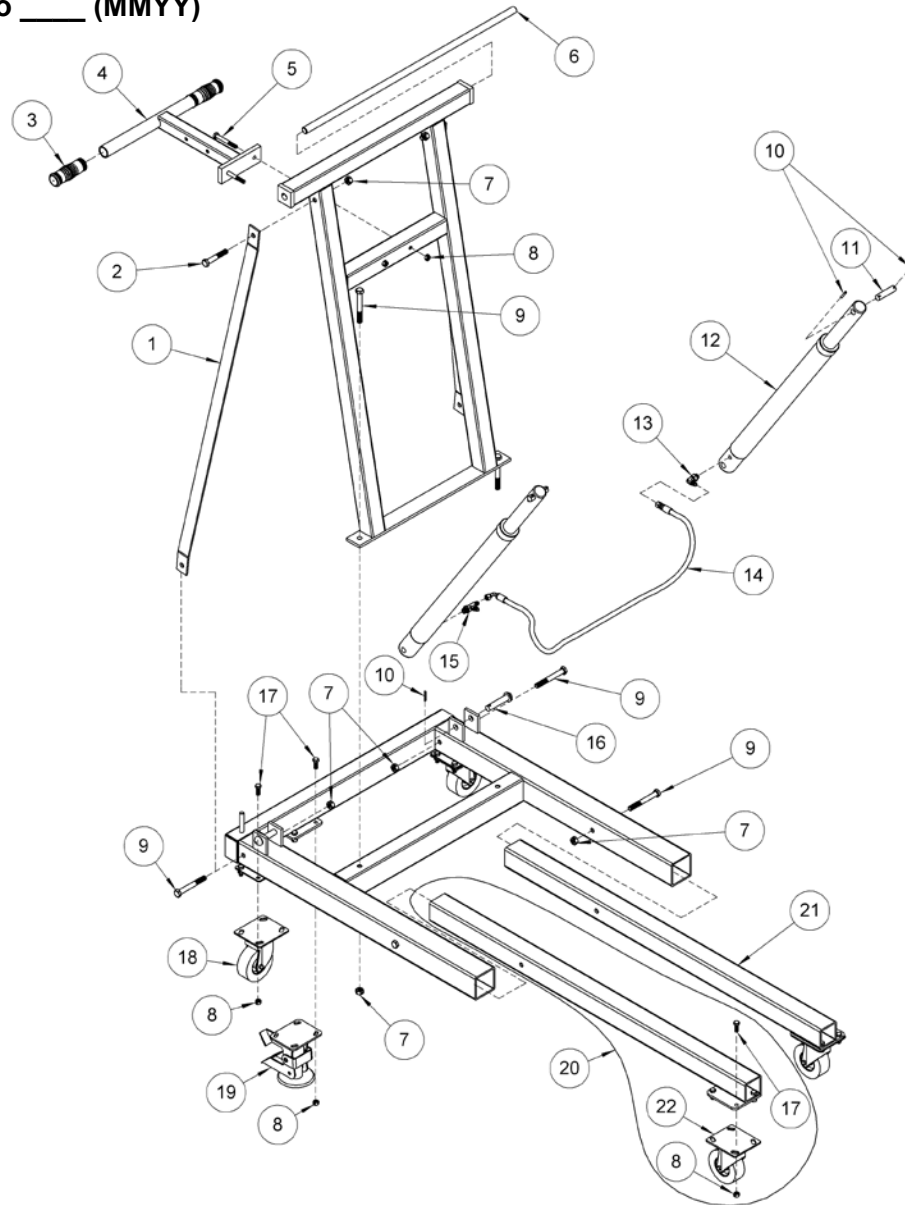

ITEM	QTY.	PART #	DESCRIPTION
1	2	4886-P	STRAP, TOWER, 410
2	2	4317-P	HHCS, 1/2-13 X 3"
3	2	83-P	GRIP, HANDLE, 1-1/4 X 4-1/2
4	1	4872W-P	WELD, HANDLE, 410
5	2	1521-P	3/8 - 16 X 3" HHCS GR 5
6	1	4871-P	SHAFT, PIVOT, 3/4 X 32", 410
7	8	810-P	NUT, 1/2-13 REV HEX LOCK
8	22	1169-P	3/8 - 16 REV HEX LOC NUT
9	6	4316-P	HHCS, 1/2-13 X 4"
10	6	64-P	ROLL PIN, 3/16 X 1-1/4
11	2	8260-P	PIN, CLEVIS, CYL, 5/8, 82

ITEM	QTY.	PART #	DESCRIPTION
12	2	781-P	CYLINDER, 1.5 X 22.625", SAE
13	1	3610-P	HYD FIT, MALE ELBOW, SAE
14	1	5023-P	HYD HOSE ASM, 36", 410
15	1	4597-P	HYD FIT, SAE TEE
16	2	138-P	CLEVIS PIN 5/8 X 3"
17	20	1572-P	3/8 - 16 X 1" HHCS GR 2
18*	2	4325-P	CASTER, SWIVEL, 4" NYLON, 410
19	1	2386-P	FLOOR LOCK, STEP DOWN 5-3/4"
20	1	4883R-P	LEG ASM, RIGHT, 410
21	1	4883L-P	LEG ASM, LEFT, 410
22*	1	4324-P	CASTER, RIGID, 4" NYLON, 410

\* Recommended spare parts