

Morse Part # 4519M-72-P Overhead Assembly used on
72" Hydra-Lift Karriers with Spark Resistant Parts and Manual Tilt
with Serial Number 1210 to ____ (MMYY)

IMPORTANT



NOTE: Serial numbers are simply the month and year of manufacture.

Example: 0802 is August 2002

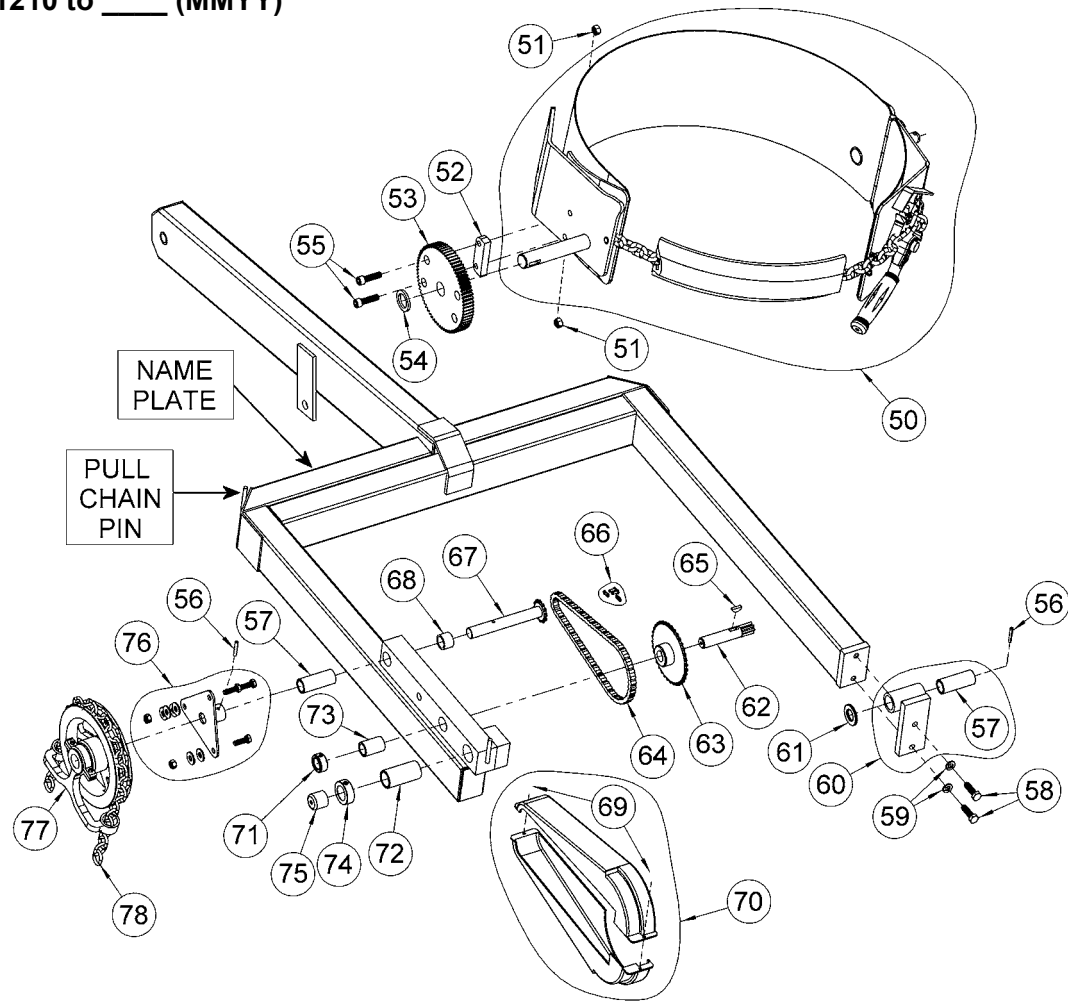

ITEM	QTY.	PART #	DESCRIPTION
50	1	5000M-P	SADDLE ASM, MORCINCH, MOR
51	2	1169-P	NUT, 3/8-16 REV HEX LOCK
52	1	4473-P	SPACER, SPUR GEAR, MOR
53*	1	23-P	GEAR, SPUR, 72T, 1" HOLE
54	1	29-P	SPACER, SPUR GEAR .15"
55	2	4370-P	SHCS, 3/8-16 X 1-3/8
56*	2	64-P	ROLL PIN, 3/16 X 1-1/4
57*	2	19-P	BEARING, 3/4" ID X 2-1/2"
58	2	535-P	HHCS, 3/8-16 X 1-1/4 GR5
59	2	1474-P	WASHER, 3/8 SPLIT LOCK
60*	1	3849B-P	BEARING ASM, SLIDING IDLER
61	1	55-P	WASHER, 3/4 SAE FL 1-1/2 OD
62*	1	14-P	GEAR, PINION, 7 TOOTH
63*	1	13-P	SPROCKET #35 36T, 3/4" BORE
64*	1	12-P	CHAIN, ROLLER, #35 W/ M LINK

ITEM	QTY.	PART #	DESCRIPTION
65*	1	735-P	KEY, WOODRUFF, SIZE 9, ASA606
66	1	795-P	LINK, MASTER, #35 CHAIN
67*	1	1302-P	SHAFT W/ 12T SPROCKET, POCKET
68*	1	1411-P	SPACER, SHAFT W/ 12T SPROCKET
69	2	2182-P	WIRE / CABLE TIE, 4-33/64 (NOT SHOWN)
70	1	4285-P	COVER SET, 30:1 GEARS, REG
71	1	15-P	COLLAR, 3/4" ID
72*	1	18-P	BEARING, 1" ID X 2-1/2"
73*	1	7-P	BEARING, 3/4" ID X 1-1/2"
74	1	16-P	COLLAR, 1" ID
75	1	4235-P	CAP, PLASTIC, DRIVE SHAFT
76*	1	3M-P	TRIANGLE W/ TUBE & BOLTS, SR
77*	1	1-P	CHAIN WHEEL #1-1/2 W/ GUIDE SR
78*	1	2541-P	CHAIN, PULL, BRASS, 1/0, 7'

* Recommended spare parts.