

Operator's Manual
for Morse Tilt-To-Load Drum Rotators
310 Series

Serial Number 250336 to _____

Contents

	Page
Receiving Procedures.	1
Warranty.	1
Safety Information.	1 - 2
Machine Description.	3 - 4
Installation.	3
Operating Instructions.	4 - 5
Maintenance.	4
Parts Lists and Diagrams.	5 - 13
Recommended Spare Parts.	14

Receiving Procedures

Every Morse drum handler is inspected prior to shipping. However, damage may be incurred during transit.

- Check for visible damage. If you choose to accept damaged freight, always sign noting the damage on the **Bill of Lading**.
- Document the damage and have the truck driver sign. We recommend keeping a digital camera at your receiving dock for this purpose.
- Open packages expeditiously to check the condition of the goods. There is only a 24 hour window to notify the carrier of any concealed damage.
- Immediately **report all damage to the shipping company!** Then you may contact Morse for assistance with your freight claim.
- Morse Manufacturing will not be held responsible for any damaged freight that is not signed for as damaged.

Limited 2 Year Warranty

Morse drum handling equipment is guaranteed against defects in workmanship or materials for two years when used properly within its rated capacity. Warranty does not cover wear from normal use or damage from accident or abuse. Motors and other purchased parts carry the warranties of their manufacturers.

For warranty claims, contact your Morse Dealer to obtain a return authorization number, and for return freight advice. Return freight must be prepaid.

In all instances, liability is limited to the purchase price paid or to repairing or replacing the product. Customer assumes liability for any modifications, unauthorized repairs or parts substitution.



Safety Information

While Morse Manufacturing Co. drum handling equipment is engineered for safety and efficiency, a high degree of responsibility must be placed upon the machine operator to follow safe practices, based primarily on common sense, upon which true safety depends.

Failure to follow the safety precautions in this manual can result in personal injury or property damage. Observe the same precautions as with similar machinery where carelessness in operating or maintenance is hazardous to personnel. Carefully read the safety precautions below and throughout this manual.

Review the Material Safety Data Sheet(s) for the material(s) in the drum(s) and take all necessary precautions. Safety shoes, work gloves, hard hat and other personal protective devices are recommended.

Prior to initial use, inspect all moving parts and test rotation of drum holder. Inspect drum holder for proper operation. Perform necessary inspections, operator training, etc.

Operator's Manual for Morse 310 Series Tilt-To-Load Drum Rotators
Serial Number 250336 to _____

Safety Information (continued)



DANGER - Indicates a situation which, if not avoided, will result in serious injury or death. This signal word is limited to the most extreme situations.



WARNING - Indicates a situation which, if not avoided, could result in serious injury or death.



CAUTION - Indicates a situation which, if not avoided, can result in damage to the machine.



DANGER - Watch Out for Pinch Points. Stay clear of moving parts. Do Not Stand Near any Part of a Rotating Drum or Drum Holder. Operator should remain directly in front of the control station while operating the rotator (see figure on page 3). Morse Drum Rotators do not comply with OSHA unless they are installed in accordance with OSHA subpart O, 1910.212 - "General requirements for all machines." "Revolving drums, barrels, and containers shall be guarded by an enclosure which is interlocked with the drive mechanism, so that the barrel, drum, or container cannot revolve unless the guard enclosure is in place." (An optional safety enclosure can be ordered for any MORSE drum rotator.)



WARNING - The 310 Series is designed to rotate a steel, plastic or fiber drum weighing up to 800 Lb., ranging from 18" to 23.5" in diameter and from 29" to 37" in height. DO NOT attempt to handle any other type of drum or object. DO NOT exceed the weight capacity of 800 Lb.



WARNING - Level Floors Only. For operation only on clean, level floors of suitable bearing capacity. Do not use on sloped surfaces, ramps, irregular or debris strewn floors.



WARNING - Properly Mount to Floor. Do Not put into service without proper floor mounting and leveling. Use the four mounting holes in each corner of the base to anchor to floor.



WARNING - Do Not Modify the Unit. Under no circumstances should any modifications be made to the Morse machinery without factory authorization. Any modifications may void the warranty. This machine was designed to perform a specific job and alterations may result in injury to operator or machine.



WARNING - No Loose Fitting Clothing Wear close-fitting clothing and safety equipment appropriate to the job. Loose fitting clothing may become caught on the machinery and cause severe personal injury.



WARNING - Hydraulic Fluid Under Pressure Can Be Hazardous. Escaping hydraulic fluid under pressure can penetrate the skin, causing serious injury. Avoid the hazard by relieving pressure before disconnecting hydraulic lines. Keep hands and body away from pinholes and nozzles which eject fluid under high pressure. Use a piece of cardboard to search for leaks. If an accident occurs, see a doctor immediately and inform them of the nature of the accident.



CAUTION - Wear safety shoes with non-slip soles and hard toe protection.



CAUTION: DO NOT allow drum to impact on floor.

Operator's Manual for Morse 310 Series Tilt-To-Load Drum Rotators Serial Number 250336 to _____

Machine Description

The Morse 310 Series Tilt-to-Load Drum Rotators are designed to receive an upright steel, plastic or fiber drum at floor level, hydraulically tilt up to clear the floor, and rotate the drum "corner-over-corner" between 5 and 20 RPM (4 to 16 RPM with 50Hz models). The maximum full drum capacity is 800 Lb. Capacity is derated to 400 Lb. for a half-full drum. Half-full Capacity is an indication of the capacity for tilting a bottom-heavy drum. A partially full drum with an unbalanced and shifting load is harder to tilt than a full drum.

See [VIDEO online](#)



Controls

There are two powered functions for the operator to control. Each function is controlled separately by levers mounted on the control station (shown right).

1. The "LIFT" function, for vertical positioning of the drum holder. The lever on the right side is the "LIFT" control valve. Raising the lever causes the drum holder to rise. Lowering the lever will lower the drum holder.
2. The "ROTATE" function, or the rotation of the drum holder. The lever on the left side is the "ROTATE" control valve. Raising this lever causes the drum holder to rotate. Lowering the lever away from the operator will stop the drum holder from rotating. The rotation speed can be varied with the flow control valve (item 13 on page 9). Turn the valve clockwise to increase speed up to a nominal 20 RPM, counterclockwise to decrease speed down to a nominal 5 RPM.

Drum Holder

The drum holder is the component on the Tilt-To-Load Drum Rotator that securely holds the drum for rotating. The drum holder features the ratchet and cinch chain mechanism for tightening the drum at the middle and two top clamps for holding the drum end-to-end.

Installation

Tilt-To-Load Rotators are shipped filled with 5-gallons of hydraulic fluid (Dexron 3 or equivalent). The base has four holes spaced 36" wide x 59-1/2" long. Morse recommends the rotator be secured to the floor using 5/8" x 3" lag bolts. Install all Morse Rotators in accordance with OSHA requirements for enclosure and safety interlock, etc. Drum rotator must automatically turn off when enclosure door is opened.

Install hydraulic levers and reservoir breather BEFORE operation.

Control Station - Making Connections:

- For the air motor powered rotator, a filter, regulator, lubricator is mounted on the control station. A shutoff ball valve is installed on the inlet of the regulator. The air connection should be made at the inlet of this valve.
- Ensure that the supply air lines are of sufficient size to provide proper air volume. The air motor requires 60 scfm, and 50 – 60 psi of compressed air. (The proper air pressure will depend on the weight of the drum.)

Important

1. Review the Material Safety Data Sheet(s) for the material(s) in the drum(s) and take all necessary precautions. Safety shoes, work gloves, hard hat and other personal protective devices are recommended.
2. Please read all instructions thoroughly before attempting to operate your new Morse drum handler.
3. When loading, unloading, operating, or maintaining your MORSE drum handler, always use care and good judgment. Maintain secure footing and a firm hold. Keep hands and loose clothing away from all moving parts. Never allow anyone to be below any part of a raised drum handler or drum. Read operating instructions and review the pictures in the sales brochure before operation.

Model #	Motor Style	Phase	Volts	Hz	Amp Draw	Drum RPM
310-1-115	TEFC	1	115	60	23	5 to 20
310-1-230	TEFC	1	230	60	11.5	5 to 20
310-3-230	TEFC	3	230	60	5.8	5 to 20
310-3-460	TEFC	3	460	60	2.9	5 to 20
310-3-575	TEFC	3	575	60	2.1	5 to 20
310-A	Air Motor	Air Motor Technical Info				5 to 20
310-E1-115	Explosion Proof *	1	115	60	23	5 to 20
310-E1-230	Explosion Proof *	1	230	60	11.5	5 to 20
310-E3-230	Explosion Proof *	3	230	60	5.8	5 to 20
310-E3-460	Explosion Proof *	3	460	60	2.9	5 to 20
310-1-220-50	TEFC	1	220	50	9.7	4 to 16
310-3-220-50	TEFC	3	220	50	5.6	4 to 16
310-3-380-50	TEFC	3	380	50	3.2	4 to 16
310-3-440-50	TEFC	3	440	50	2.8	4 to 16
310-E1-220-50	Explosion Proof *	1	220	50	9.7	4 to 16
310-E3-220-50	Explosion Proof *	3	220	50	5.6	4 to 16
310-E3-380-50	Explosion Proof *	3	380	50	3.2	4 to 16
310-E3-440-50	Explosion Proof *	3	440	50	2.8	4 to 16

* Explosion Proof Motors are rated for Class I Group D, and Class II Groups F and G.



Control Station



Man at Control Station

START UP PROCEDURES

PUMP ROTATION IS CLOCKWISE VIEWING FROM THE MOTOR END. JOG THE MOTOR TO DETERMINE PROPER ROTATION. IN THE EVENT FLUID DOES NOT FLOW, CHECK MOTOR WIRING DIAGRAM FOR CLOCKWISE ROTATION.

Operator's Manual for Morse 310 Series Tilt-To-Load Drum Rotators
Serial Number 250336 to _____

Loading a Drum

1. With the drum holder in the lowered position, the bottom loading plate will be slightly above the floor. Swing the hinged ratchet plate clear of the drum opening. Loosen the top clamps to the full open position.
2. A variety of drum handling methods can be used to set the drum into the drum holder (see images below). Ensure that the drum is fully seated against the back of the drum holder.



Load drum with drum truck



Load drum with model 81 Drum Spotter



Load drum with hoist attachment

3. Drape the cinch chain across the face of the drum and engage a link in notch in hub of ratchet. Turn ratchet until chain tightens around drum.
4. Turn the top clamps until they tighten against top of drum.



Rotating a Drum

1. After ensuring that the drum is securely fastened into the drum holder, turn the motor on to activate the hydraulics (for the air motor version, open the air shutoff ball valve).
2. Raise the drum to the top position by raising the LIFT control valve, on the right.



DANGER - It is critical that the drum holder assembly is fully raised **BEFORE** rotating. If the drum holder is not in the fully raised position when rotating, it can interfere with the floor and frame, causing severe damage to equipment and/or serious injury or death.

Note: There is an interlock switch built into the tilt frame which is intended to prevent rotating when the drum holder is not properly positioned at it's highest lift point. The true safety of this operation, however, depends on the operator correctly positioning the drum holder, and verifying that the tilt frame is fully raised.

To begin rotating, raise the ROTATE control valve.

Alternate method: On the air motor version: With the air shutoff ball valve in the OFF position, raise the ROTATE valve to the ROTATE position. Then, slowly open the air shutoff ball valve to begin the rotation. This can allow for more control over the speed of rotation.

Unloading a Drum

Ensure the drum is in vertical upright position to unload.

Maintenance

Periodic inspection for the general condition of structural and mechanical components is imperative for safe and efficient operation.

1. Inspect the hydraulic system for oil drips, hose damage, or other signs of wear. Inspect the level and condition of the hydraulic fluid. Replace any parts that show signs of wear.
2. Lubricate all moving parts including: bearings, clevis pins, and threaded rod.
3. Periodically inspect all moving parts, framework, and floor mounting fasteners for signs of wear, fatigue, or loosening.

Operator's Manual for Morse 310 Series Tilt-To-Load Drum Rotators
Serial Number 250336 to _____

Drum Holder (Saddle) Assembly
Part # 4551-P

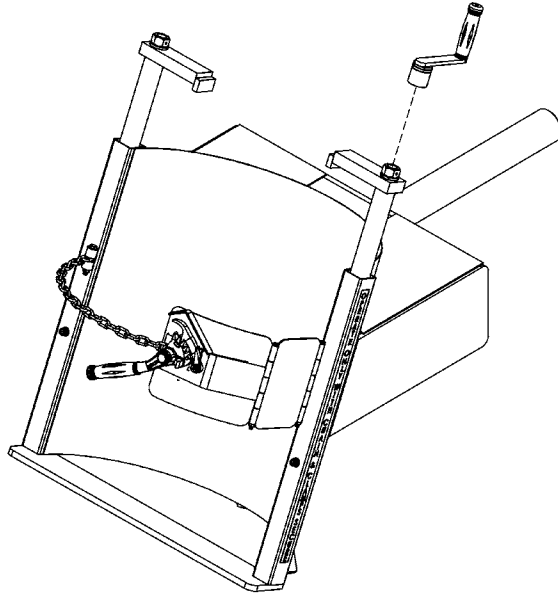

Tilt Assembly
(not sold separately)

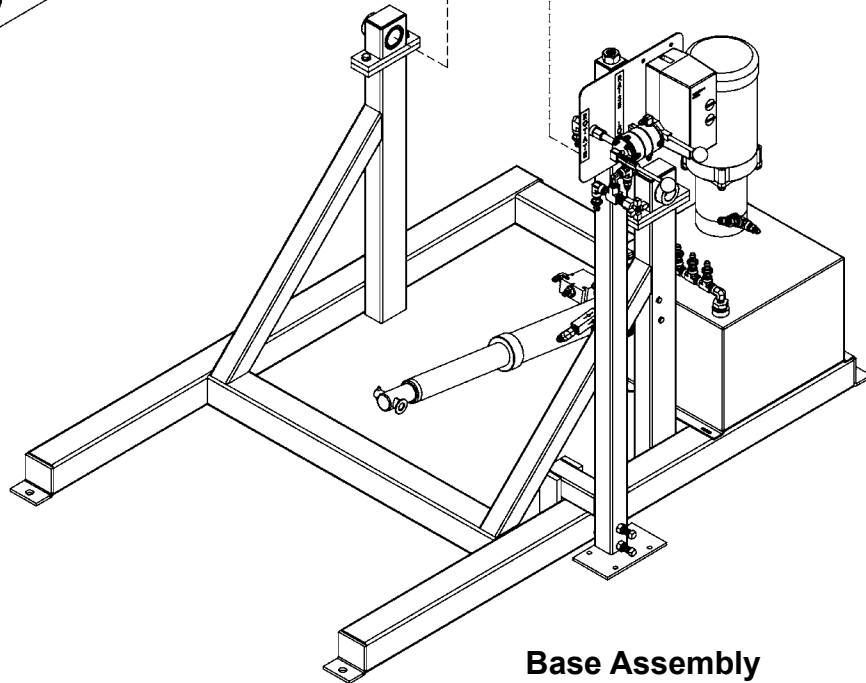
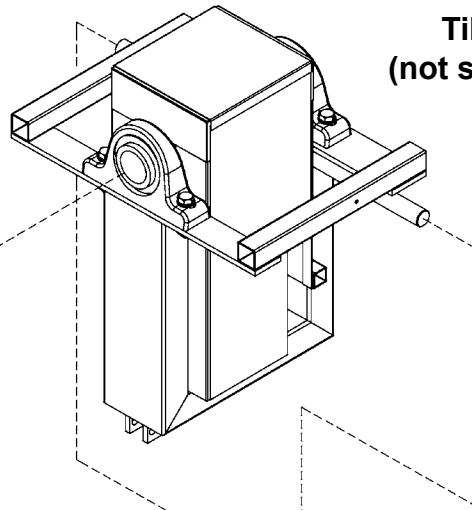

Base Assembly
(not sold separately)

Operator's Manual for Morse 310 Series Tilt-To-Load Drum Rotators
Serial Number 250336 to _____

Base Assembly

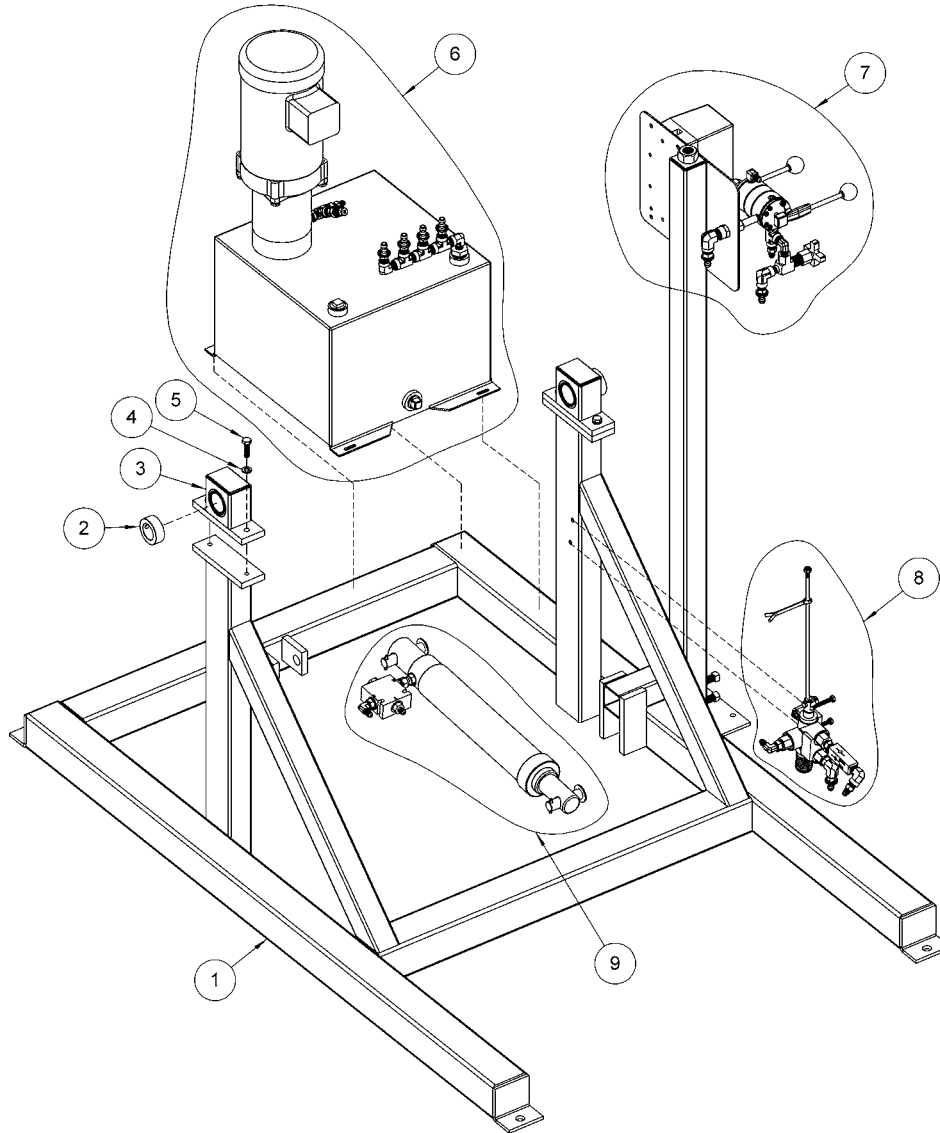

ITEM	QTY.	PART #	DESCRIPTION
1	1	4920-P	BASE WELD, 310
2	2	570-P	COLLAR, 1-1/2" ID
3	2	3520-P	IDLER BEARING ASM W/ CAP 310
4	4	1474-P	WASHER, 3/8 SPLIT LOCK
5	4	535-P	HHCS, 3/8-16 X 1-1/4 GR5
6	1	NA	310 HYDRAULIC POWER PACK
7	1	NA	310 CONTROL PLATE ASM.
8	1	NA	310 SAFETY LIMIT VALVE
9	1	NA	310 CYLINDER ASSEMBLY

* Recommended spare parts

Operator's Manual for Morse 310 Series Tilt-To-Load Drum Rotators
Serial Number 250336 to _____

Cylinder Assembly

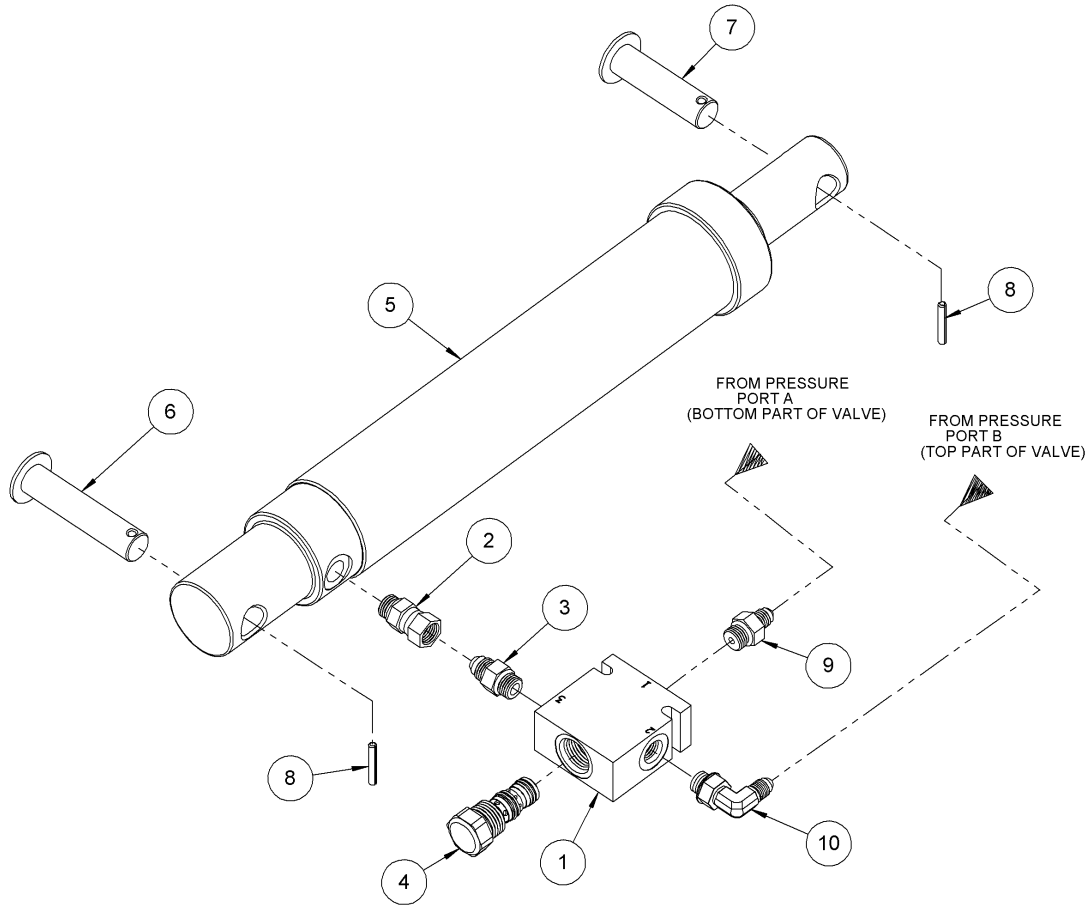

ITEM	QTY.	PART #	DESCRIPTION
1	1	4576B-P	BODY, PO CHECK, 310
2	1	4594-P	HYD FIT, SAE STRAIGHT SWIVEL
3	1	4593-P	HYD FIT, SAE STRAIGHT
4	1	4576C-P	CART, PO CHECK, 310
5	1	4572-P	CYLINDER, 2 X 10.5, 310
6	1	3275-P	CLEVIS PIN WELD, DEAD END 310
7	1	3276-P	CLEVIS PIN WELD, LIVE END 310
8	2	64-P	ROLL PIN, 3/16 X 1-1/4
9	1	3612-P	HYD FIT, SAE ADAPTER
10	1	3610-P	HYD FIT, MALE ELBOW, SAE

* Recommended spare parts

Operator's Manual for Morse 310 Series Tilt-To-Load Drum Rotators Serial Number 250336 to _____

Safety Limit Valve Assembly

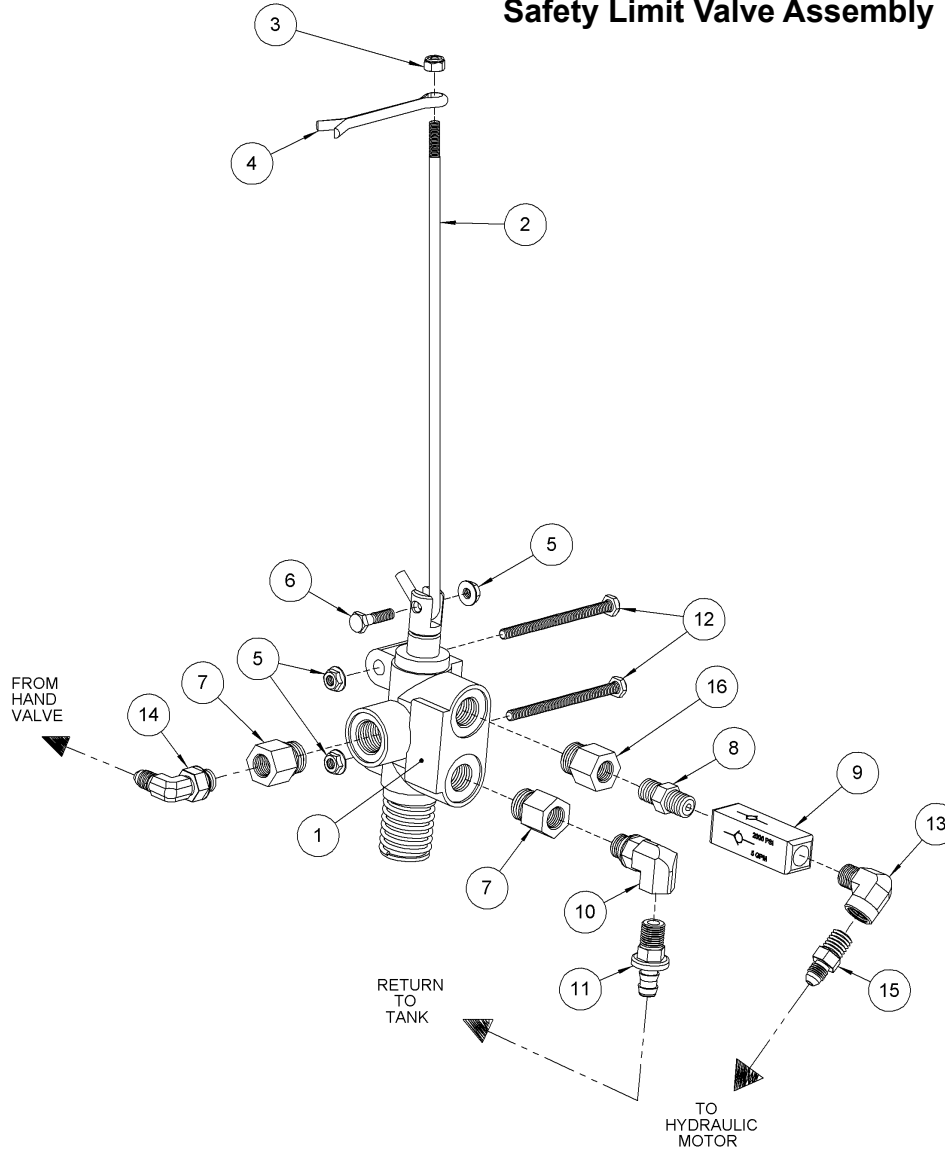

ITEM	QTY.	PART #	DESCRIPTION
1	1	4859-P	SAFETY LIMIT VALVE, 310
2	1	4922-P	LINK, SAFETY LIMIT VALVE 310
3	1	4250-P	NUT, 1/4-28 NYLON LOCK
4	1	4249-P	COTTER PIN, 1/4" X 2-1/2"
5	3	3923-P	NUT, 1/4-20 WHIZ LOCK
6	1	1641-P	HHCS, 1/4-20 X 1 GR2
7	2	4860-P	FIT, ADAPTOR, SAE, 310
8	1	1108-P	HYD FIT, PIPE NIPPLE, 1/4

ITEM	QTY.	PART #	DESCRIPTION
9	1	4027-P	CHECK VALVE, 310
10	1	3757-P	HYD FIT, SAE ELBOW, 456 CYL
11	1	1107-P	HYD FIT, PUSH LOK 1/4 X 3/8
12	2	4923-P	HHCS, 1/4-20 X 3-1/2 GR
13	1	2118-P	HYD FIT, STREET ELBOW, 1/4
14	1	3610-P	HYD FIT, MALE ELBOW, SAE
15	1	345-P	HYD FIT, MALE FLARE, 456, 82
16	1	4431-P	HYD FIT, ADAPTOR, 1/4 3/4-16

Operator's Manual for Morse 310 Series Tilt-To-Load Drum Rotators Serial Number 250336 to _____

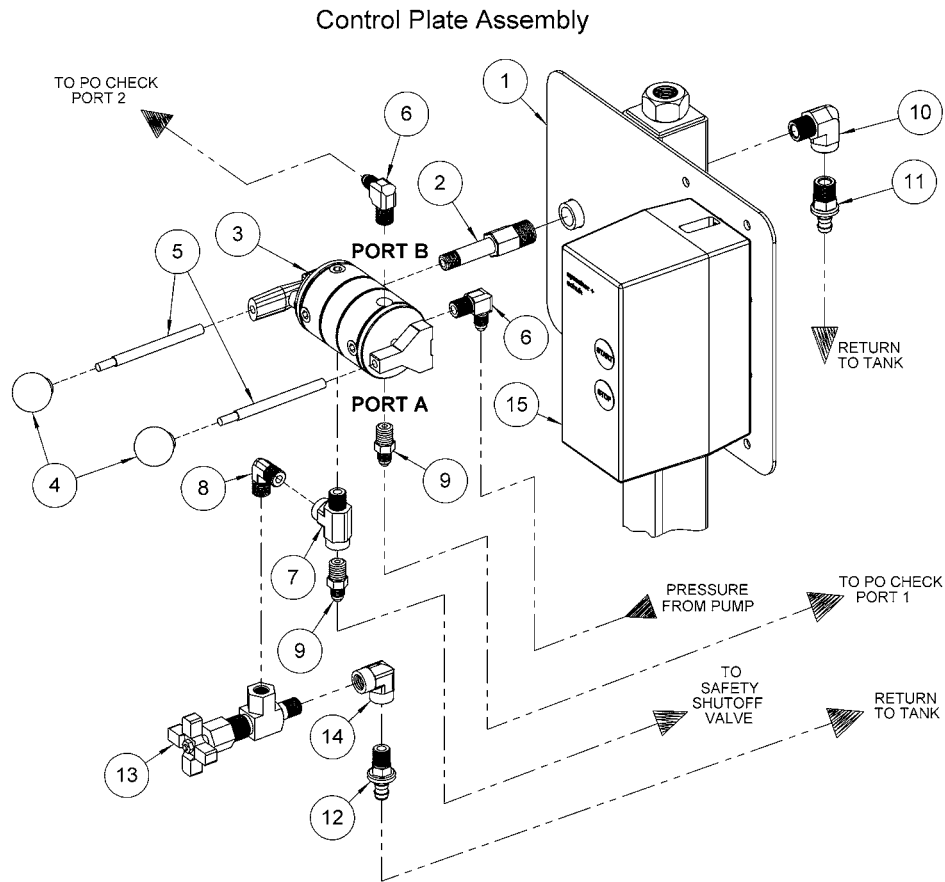

ITEM	QTY.	PART #	DESCRIPTION
1	1	4928-P	MAST ASM, 310
2	1	M01319-P	PUMP VALVE ADAPTOR, 3-3/8
3	1	M07381-P	VALVE, 3-4 WAY ROUND ROUND 456
4 *	2	M01157-P	BALL, PLASTIC, HANDLE, MONARCH
5 *	2	M01326-P	ROD, VALVE HANDLE, MONARCH
6	2	765-P	HYD FIT, MALE ELBOW, FLARE 400
7	1	1105-P	HYD FIT, RUN TEE, 456, 310
8	1	2119-P	HYD FIT, MALE PIPE ELBOW, 456
9	2	345-P	HYD FIT, MALE FLARE, 456, 82
10	1	3301-P	HYD FIT, STREET ELBOW, 3/8 310
11	1	2519-P	HYD FIT, PUSH LOK 3/8 X 3/8
12	1	1107-P	HYD FIT 1/8 X 3/8 PUSH LOK 310
13	1	4772-P	VALVE, METERING, 310
14	1	4776-P	HYD FIT, ELBOW, 1/4

* Recommended spare parts

ITEM 15 - CONTROL BOX		
MODEL #	PART #	DESCRIPTION
310-1-115	3213-P	CONTROL BOX, 310-1-115
310-1-230	3214C-P	CONTROL BOX, 310-1-230 CAGE
310-3-230	3215C-P	CONTROL BOX, 310-3-230 CAGE
310-3-460	3216C-P	CONTROL BOX, 310-3-460 CAGE
310-3-575	3216C-P	CONTROL BOX, 310-3-460 CAGE
310-A	90020-P	KIT, 3/8" FRL & B-VLV PRE 0702
310-E1-115	3818-P	CONTROL BOX, 310-E1-115
310-E1-230	3814-P	CONTROL BOX, 456-E1 310-E1-230
310-E3-230	3819-P	CONTROL BOX, 310-E3-230
310-E3-460	3816-P	CONTROL BOX, 456-E3 310-E3-460
310-1-220-50	3214C-P	CONTROL BOX, 310-1-230 CAGE
310-3-220-50	3215C-P	CONTROL BOX, 310-3-230 CAGE
310-3-380-50	4030C-P	CONTROL BOX, 456-3-380-50 CAGE
310-3-440-50	3216C-P	CONTROL BOX, 310-3-460 CAGE
310-E1-220-50	3814-P	CONTROL BOX, 456-E1 310-E1-230
310-E3-220-50	3819-P	CONTROL BOX, 310-E3-230
310-E3-380-50	3816-P	CONTROL BOX, 456-E3 310-E3-460
310-E3-440-50	3816-P	CONTROL BOX, 456-E3 310-E3-460

Operator's Manual for Morse 310 Series Tilt-To-Load Drum Rotators Serial Number 250336 to _____

Hydraulic Power Pack Assembly

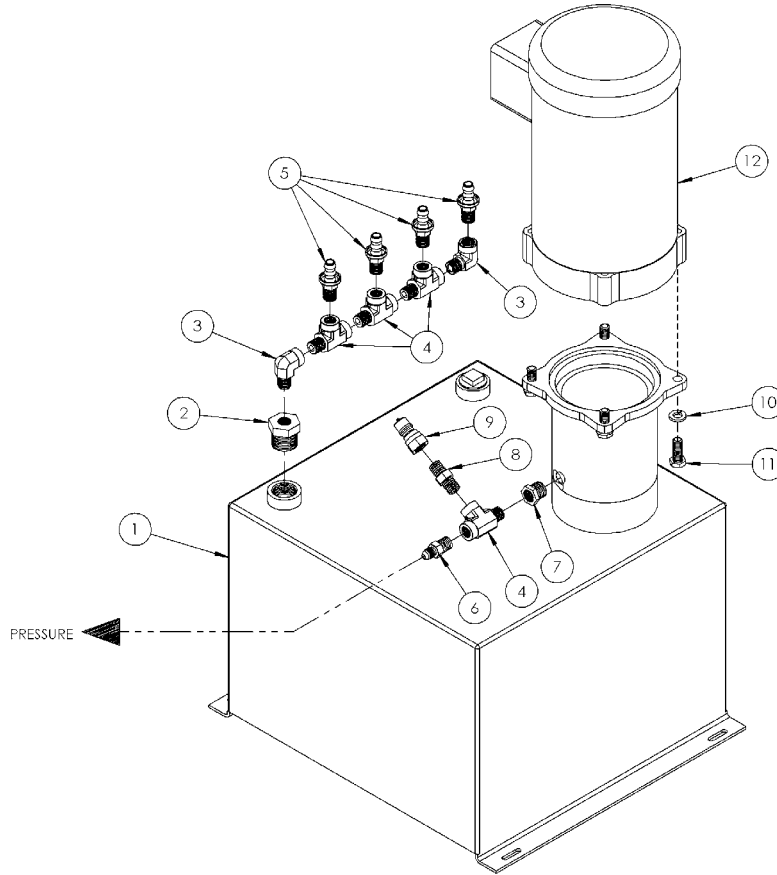

ITEM	QTY.	PART #	DESCRIPTION
1 **	1	M404-310-P	HYD POWER PACK, 310
2	1	4008-P	FIT, PIPE REDUCER, 3/4-1/4 310
3	2	2118-P	HYD FIT, STREET EL, 1/4
4	4	1105-P	HYD FIT, RUN TEE, 456, 310
5	4	1107-P	HYD FIT, 1/4 X 3/8 PUSH LOK
6	1	345-P	HYD FIT, MALE FLARE, 456, 82
7	1	3299-P	PIPE THREAD REDUCER, 3/8, 310
8	1	1108-P	HYD FIT, PIPE NIPPLE, 1/4"
9	1	3596-P	HYD FIT, QUICK 1/4 NIPPLE, 310
10	4	1474-P	WASHER, 3/8 SPLIT LOCK
11	4	1572-P	3/8 - 16 X 1" HHCS GR 2
12	1	SEE RIGHT	MOTOR

* Recommended spare parts

** Includes items 2, 3, 4 and 5 on page 9.

ITEM 12 - MOTOR		
MODEL #	PART #	DESCRIPTION
310-1-115	3186-1-P	MOTOR, 2HP, 1PH, 3450 RPM
310-1-230	3186-1-P	MOTOR, 2HP, 1PH, 3450 RPM
310-3-230	3186-3-P	MOTOR, 2HP, 3PH, 3450 RPM
310-3-460	3186-3-P	MOTOR, 2HP, 3PH, 3450 RPM
310-3-575	3186-575-P	MOTOR, 2HP, 3PH, 3450 RPM 575V
310-A	290-A-2P	MOTOR, 2HP, AIR, 56C
310-E1-115	3186-E1-P	MOTOR, 2HP, 1PH, 3450 RPM EXP
310-E1-230	3186-E1-P	MOTOR, 2HP, 1PH, 3450 RPM EXP
310-E3-230	3186-E3-P	MOTOR, 2HP, 1PH, 3450 RPM EXP
310-E3-460	3186-E3-P	MOTOR, 2HP, 1PH, 3450 RPM EXP
310-1-220-50	3186-1-50-P	MOTOR, 2HP, 1PH, 2850 RPM 50HZ
310-3-220-50	3186-3-50-P	MOTOR, 2HP, 3PH 2850 RPM 50HZ
310-3-380-50	3186-3-50-P	MOTOR, 2HP, 3PH 2850 RPM 50HZ
310-3-440-50	3186-3-50-P	MOTOR, 2HP, 3PH 2850 RPM 50HZ
310-E1-220-50	3186-E1-50-P	MOTOR, 2HP, 1PH, 2850 50HZ EXP
310-E3-220-50	3186-E3-50-P	MOTOR, 2HP, 3PH, 2850 50HZ EXP
310-E3-380-50	3186-E3-50-P	MOTOR, 2HP, 3PH, 2850 50HZ EXP
310-E3-440-50	3186-E3-50-P	MOTOR, 2HP, 3PH, 2850 50HZ EXP

Operator's Manual for Morse 310 Series Tilt-To-Load Drum Rotators Serial Number 250336 to _____

Tilt Assembly

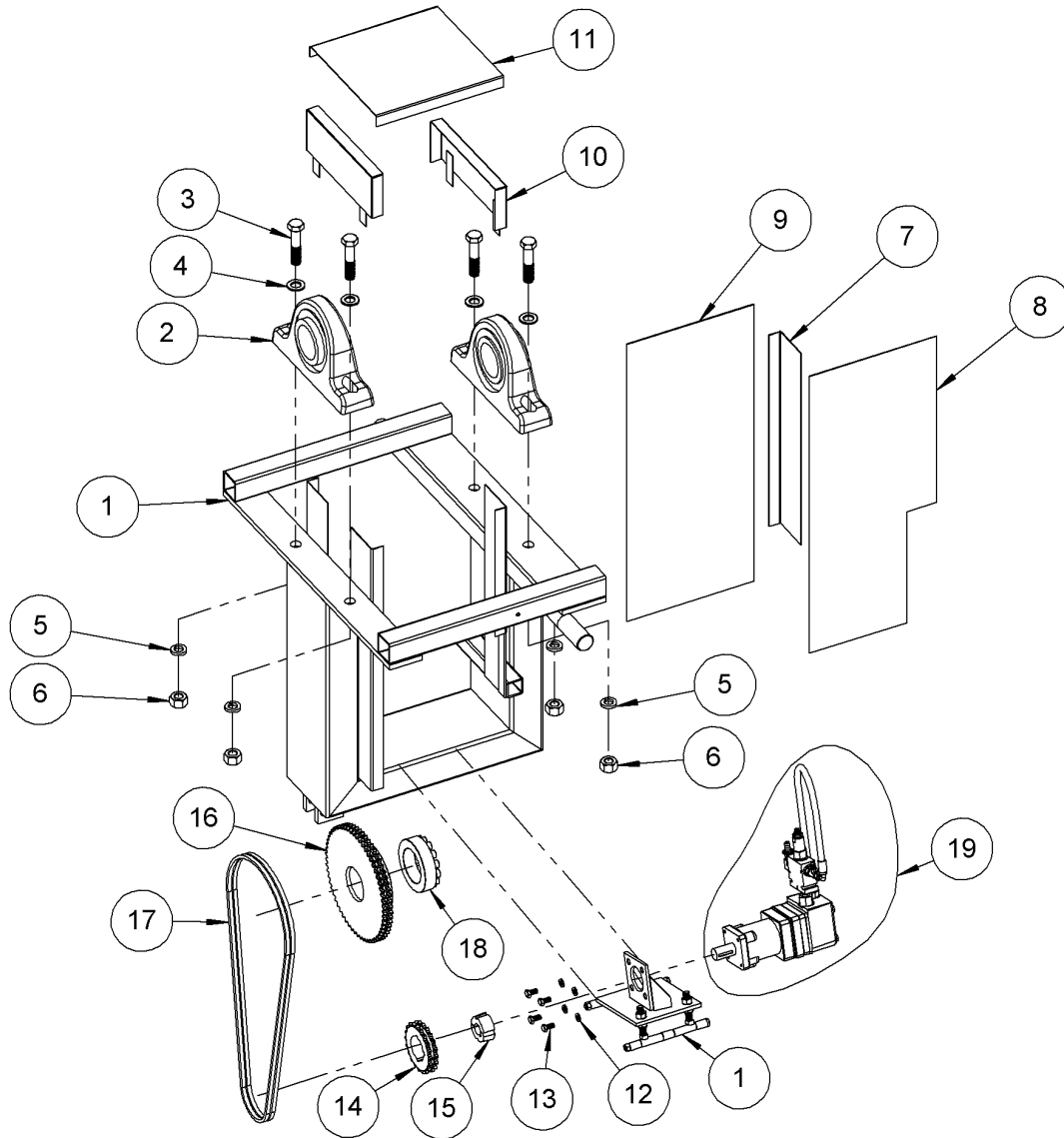

ITEM	QTY.	PART #	DESCRIPTION
1	1	3081-P	TILT WELD, 310
2 *	2	2654-P	BEARING, 2-15/16" PILLOW BLOCK
3	4	3318-P	HHCS, 3/4-10 X 3-1/2 GR5
4	4	55-P	WASHER, 3/4 SAE FL 1-1/2 OD
5	4	3319-P	WASHER, 3/4 SPLIT LOCK
6	4	2452-P	NUT, FIN, 3/4-10 HEX
7	1	3146-P	GUARD LOWER CORNER, SHORT, 310
8	1	3100-P	GUARD FRONT COVER, NOTCH, 310
9	1	3149-P	GUARD REAR COVER, 310
10	2	3147-P	GUARD, UPPER SIDE WELD, 310

ITEM	QTY.	PART #	DESCRIPTION
11	1	3150-P	GUARD TOP COVER, 310
12	4	1474-P	WASHER, 3/8 SPLIT LOCK
13	4	1657-P	3/8 - 16 X 3/4 HHCS GR 2
14 *	1	3127-P	SPROCKET, #40D, 20T, TAPER 310
15 *	1	3128-P	BUSHING, 1" TAPER LOCK, 310
16 *	1	3117-P	SPROCKET, #40D, 60T, 310
17 *	1	3132-P	ROLLER CHAIN, #40D 29 PITCHES
18 *	1	3124-P	HUB, 2-15/16" KEYLESS, 310
19	1	NA	COUNTER BALANCE VALVE, ASM

* Recommended spare parts

Operator's Manual for Morse 310 Series Tilt-To-Load Drum Rotators
Serial Number 250336 to _____

Counter Balance Valve Assembly

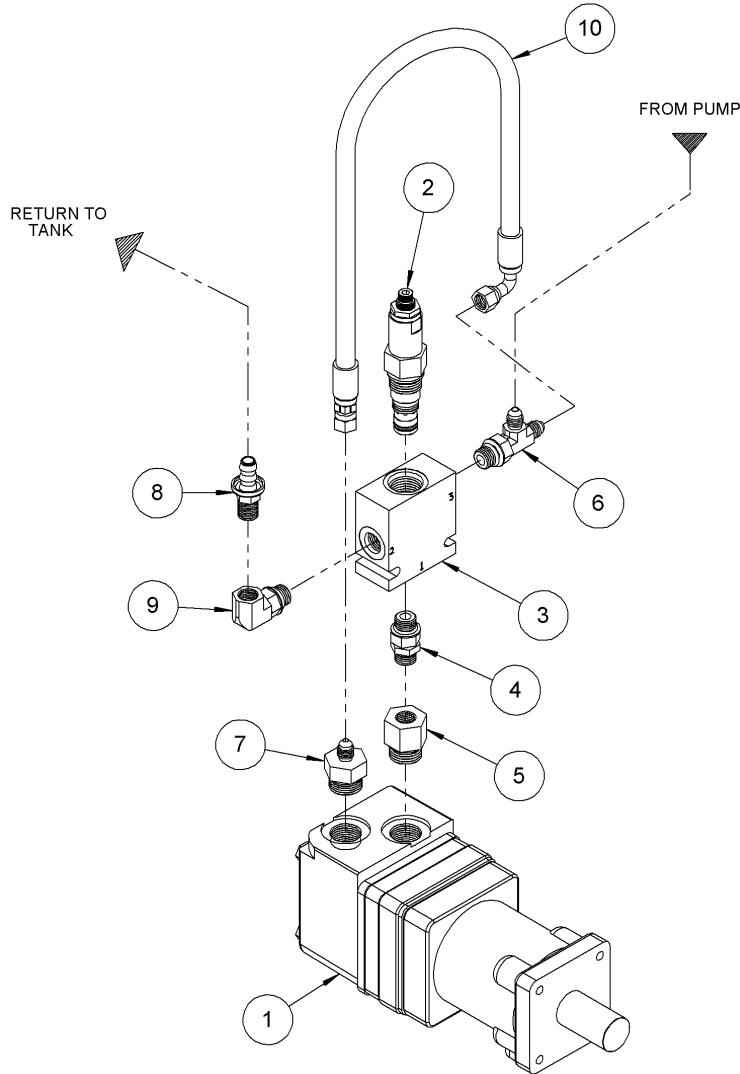

ITEM	QTY.	PART #	DESCRIPTION
1	1	3114-P	MOTOR, HYDRAULIC HYD, 310
2	1	4600-P	CARTRIDGE, CBAL 310
3	1	4576B-P	BODY, PO CHECK, 310
4	1	4599-P	HYD FIT, NIPPLE
5	1	4598-P	HYD FIT, REDUCER
6	1	4597-P	HYD FIT, SAE TEE
7	1	3154-P	HYD FIT, MALE ADAPTOR SAE, 310
8	1	1107-P	HYD FIT, 1/4 X 3/8 PUSH LOK
9	1	3757-P	HYD FIT, SAE ELBOW, 456 CYL
10	1	4627-P	HYD HOSE ASM, 20" ELBOW, 310

* Recommended spare parts

Operator's Manual for Morse 310 Series Tilt-To-Load Drum Rotators
Serial Number 250336 to _____

Drum Holder (Saddle) Assembly

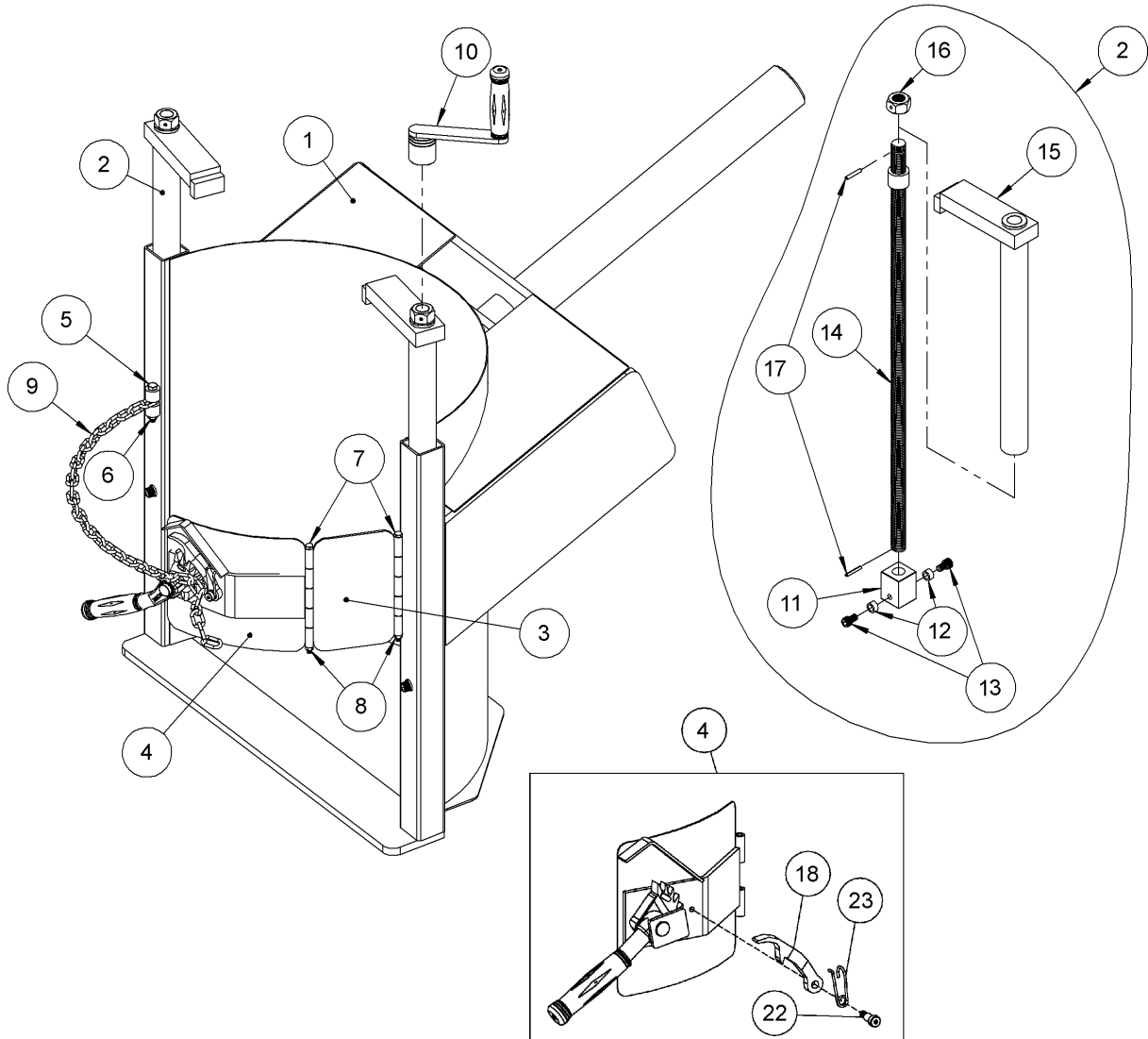

ITEM	QTY.	PART #	DESCRIPTION
1	1	4551-P	SADDLE ASM, 310
2	2	4553F-P	CLAMP WELD / SCREW ASM 310
3	1	3112-P	HINGE LINK WELD, 310
4 *	1	727A-P	RATCHET PLATE CPT W/ TAB 1/4"
5	1	4079-P	HHCS, M8 X 60 MM GR5, 8MM
6	1	4081-P	NUT, ESNA, M8, 8MM
7	2	1296-P	1/4 - 20 X 7-1/2 HHCS GR 5
8	2	1297-P	1/4 - 20 REV HEX LOC NUT
9 *	1	5017-P	CHAIN, CINCH, 9/32, 38 LINK
10	1	3145-P	HAND CRANK, W/ SOCKET, 310
11	1	3269-P	CLAMP NUT BLOCK, 310

ITEM	QTY.	PART #	DESCRIPTION
12	2	3271-P	CLAMP NUT BLOCK SPACER, 310
13	2	22-P	3/8 - 24 x 5/8" SHCS
14	1	3272-P	CLAMP SCREW WELD, 310
15	1	4553-P	CLAMP PIPE W/ BEARING WELD 310
16	1	1545-P	NUT, 7/8-9 FIN HEX
17	2	64-P	ROLL PIN, 3/16 X 1-1/4
18	1	168-P	PAWL, WITH DRILLED HOLE
21	1	136-P	HANDLE GRIP, 7/8" X 4-3/4"
22	1	170-P	3/8" DIA X 5/8" SHOULDER SCREW
23	1	169-P	SPRING, PAWL

* Recommended spare parts

Operator's Manual for Morse 310 Series Tilt-To-Load Drum Rotators
Serial Number 250336 to _____

Recommended Spare Parts Kit Number: RP310-01

Kit Description: Kit, Spare Parts for 310 Series

Qty.	Part #	Description
2	2654-P	BEARING, 2-15/16" PILLOW BLOCK
1	3127-P	SPROCKET, #40D, 20T, TAPER 310
1	3128-P	BUSHING, 1" TAPER LOCK, 310
1	3117-P	SPROCKET, #40D, 60T, 310
1	3132-P	ROLLER CHAIN, #40D 29 PITCHES
1	3124-P	HUB, 2-15/16" KEYLESS, 310
1	727A-P	RATCHET PLATE CPT W/ TAB 1/4"
1	5017-P	CHAIN, CINCH, 9/32, 38 LINK
2	M01157-P	BALL, PLASTIC, HANDLE, MON
2	M01326-P	ROD, VALVE HANDLE, MON