

Replacement Parts List for Morse Part # 648-P Hydraulic Cylinder

Used on:

- 456 Series Hydra-Lift Drum Rollers with serial numbers 206720 to _____

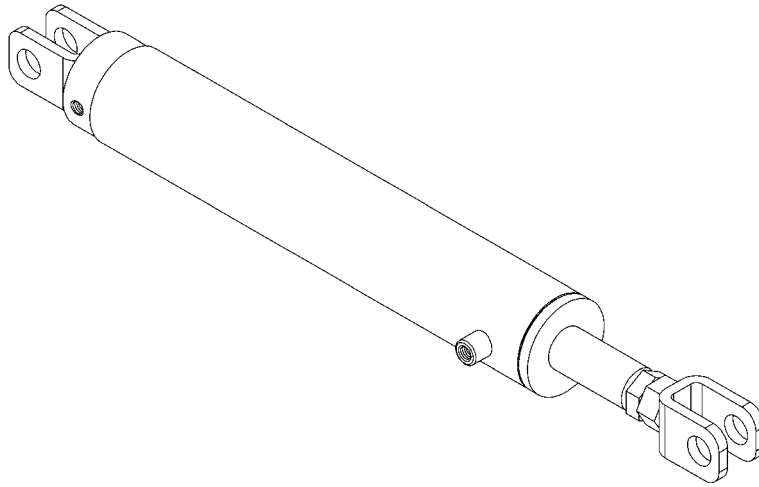

QTY.	PART #	DESCRIPTION
1	648-P	CYLINDER, 3 X 16, SAE, 456
1	4349-P	KIT, SEAL, 3" CYL., 648-P

Note: Stroke is 16" (40.6 cm)
 Length Closed: 29-1/2" (74.9 cm) Center to Center
 Length Fully Extended: 45-1/2" (115.6 cm) Center to Center