

Operators Manual for MORSE Model 125 "NO-SPILL" DRUM TRUCK Serial Number 0105 to ____ (MMYY)

OPERATING INSTRUCTIONS

- A. Move upright drum by pulling or pushing on hinged handle.
- B. Hinge allows extension of handle away from load to pivot or steer truck.
- C. Handle stores in upright position.

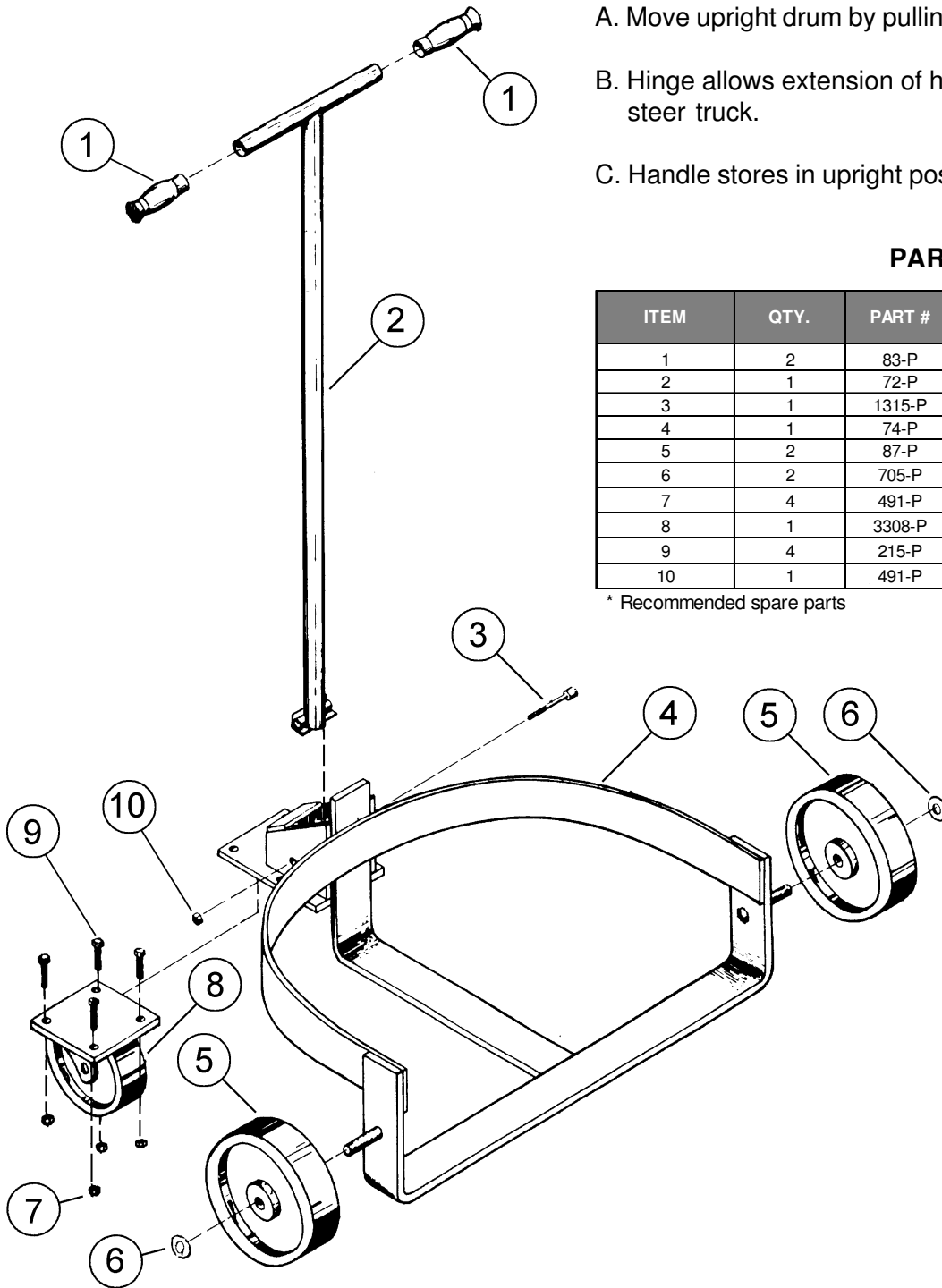

PARTS LIST

ITEM	QTY.	PART #	DESCRIPTION
1	2	83-P	HANDLE GRIP, 1-1/4 X 4-1/2
2	1	72-P	HANDLE WELD, 125
3	1	1315-P	3/8 - 16 X 2-3/4 HHCS GR 2 STL
4	1	74-P	BASE WELD, 125
5	2	87-P	WHEEL, MORTUF, 8", 3/4" BRG
6	2	705-P	PUSH-ON HUB CAP, 3/4"
7	4	491-P	5/16 - 18 REV HEX LOC NUT
8	1	3308-P	CASTER, SWIVEL 4", DOUBLE RACE
9	4	215-P	5/16 - 18 X 5/8 HHCS GR 2
10	1	491-P	5/16 - 18 REV HEX LOC NUT

* Recommended spare parts